

BRODA® **587**

Owner, Operator, and Maintenance Manual

Model 587 Manual Wheelchair



BRODA®

560 Bingemans Centre Drive Kitchener, ON Canada N2L 5R8

Can./U.S. Phone: (800)-668-0637

Fax: (519) 746-8616

www.brodaseating.com Email: sales@brodaseating.com

TABLE OF CONTENTS

WARNING

SPECIFICATIONS

GENERAL INSTRUCTIONS

SECTION 1 - SAFETY REQUIREMENTS & DETAILED WARNINGS

1.1	Before First Use WARNING	6
1.2	Application WARNING.....	6
1.3	Legal Restrictions WARNING.....	7
1.4	Position of Wheelchair “Danger of Falling” WARNING	7
1.5	Position of Seat Tilt “Danger of Tipping” WARNING.....	7
1.6	Propelling and Transferring “Danger of Tipping” WARNING	7
1.7	Wheelchair Placement “Danger of Tipping” WARNING.....	7
1.8	Locking Wheels “Danger of Falling” WARNING	8
1.9	Re-Positioning of Patient “Danger of Pinching” WARNING	8
1.10	Accidental Motion “Danger of Falling or Collision” WARNING.....	8
1.11	Improper Restraint Use “Risk of Serious Injury” WARNING	9
1.12	Improper Use WARNING	9
1.13	Cleaning WARNING	9
1.14	Preventative Maintenance WARNING.....	10
1.15	Patient Specific Instructions WARNING	11

SECTION 2 - DEFINITIONS AND TECHNICAL INFORMATION

2.1	Definitions.....	13
2.2	Technical Information	13
2.3	Shipping and Storage Specifications	14
2.4	Label Locations	15

SECTION 3 - CAREGIVER MANAGEMENT

SECTION 4 - WHEELCHAIR OPERATION

4.1	Armrests	17
4.2	Anti Tippers and Wheel Locks.....	18
4.3	Seat and Back	19
4.4	Accessories.....	20
4.5	Headrest.....	21
4.6	Solid Seat & Drop Seat and Back.....	22
4.7	Seat Height Adjustment.....	22
4.8	Seat Depth Adjustment.....	24

SECTION 5 - WHEELCHAIR REPAIR AND MAINTENANCE

5.1	Suggested Tool Kit	26
5.2	List of Commonly Replaced Parts	26
5.3	Cables and Cable Handles.....	27
5.4	Rear Wheels and Front Casters	28
5.5	Gas Cylinders	30
5.6	Vinyl Straps	32

APPENDIX 1 - BRODA WARRANTY

WARNING

DO NOT OPERATE THE BRODA 587 WITHOUT FIRST READING AND UNDERSTANDING THIS MANUAL. IF FOR ANY REASON THE WARNINGS OR INSTRUCTIONS ARE UNCLEAR, CONTACT BRODA SEATING AT 1 800 668 0637 FOR CLARIFICATION. DO NOT ATTEMPT TO USE WHEELCHAIR WITHOUT FULLY UNDERSTANDING THE WHEELCHAIR AND ITS OPERATION AS IT MAY RESULT IN INJURY OR DAMAGE.

587 SPECIFICATIONS

Item	Standard	Available Options
Weight Capacity	250 lbs	N / A
Seat Depth	17"	15.5" / 18.5" / 20" w/ strapped seat, 16", 17", 18" 19" w/ seat pan
Seat Height	15" seat pan 16" strapped seat	14", 16", 17", 18", 19", 20" seat pan 15", 17", 18", 19", 20", 21" strapped seat
Seat Width	16" / 18"	20"
Overall Height	42.5" (upright, w/o headrest)	Varies with seat height/wheel options
Overall Width	26.5" / 28.5"	30.5"
Overall Length	35" (w/o Footrests)	Up to 45.5" (w/ Footrests)
Back Height	24"	26", 28", 30"
Degrees of Tilt	Capable of 45° Tilt	
Back Angle	90°	Adjustable to 95°, 100°, 105°
Adjustable Arm Heights (variable, depending on seat height)	5.5" Range	5/8" Increments
Arm Type	Fixed Height, Swing Up Detachable	Height Adjustable, Swing Up, Detachable
Front Casters	6" Swivel	8" Swivel
Rear Wheels	22" Mag Rear Mount	20" or 24" Mag Rear Mount
Frame Color	Black Hammertone	Grey Hammertone
Weight (varies with options)	Approx 66-80 lbs	N / A
Shipping Weight	Approx 75-90 lbs	N / A
Footrest	Swing-Away / Adjustable Length	Elevating Swing Away, Angle Adjustable Footplates
Strap Color	Black	Grey / Blue / Green / Pink

GENERAL INSTRUCTIONS

The instructions contained herein provide guidance on the safe and correct operation of the BRODA Model 587 Manual Wheelchair. Safety measures as described in Section 1 must be observed when operating the wheelchair's functions or moving the wheelchair.

Every person that is involved with the operation and maintenance of the BRODA wheelchair, including the patient's family members, must read this instruction manual prior to moving or operating the functions of this wheelchair. A copy of this instruction manual must always be available to these people. No person, including the patient's family members, who is unfamiliar with or is unwilling or unable to adhere to the safety and operating instructions contained herein, should be permitted to operate or move the wheelchair.

The BRODA 587 wheelchair's intended use is to provide mobility to persons that may be limited to a sitting position. It is highly recommended that someone such as a nurse, nursing home staff or family member operate this device to transport patient(s) on even surfaces for safety and effectiveness. The BRODA Model 587 will be primarily used, but not limited to use, by residents in Nursing Homes and institutional settings. It is the responsibility of the user, with the help of his/her qualified healthcare professional, to determine the type of chair required for the individual.

The safety and operating instructions that are included in this manual are very important to the safe and effective operation of the BRODA wheelchair. Safety requirements that are detailed in Section 1 must be followed at all times.

BRODA accepts no liability whatsoever for damage or disruptions caused by operating errors, failure to provide proper maintenance, or the disregard of the instructions contained in this manual. This also includes the patient's specific instructions.

BRODA reserves the right to make changes to the specifications of the dimensions, functions, and components of its products. Any diagrams or drawings provided are not necessarily exactly the same as the delivered products.

Each BRODA wheelchair is provided with a unique, identifying serial number. This serial number should be maintained on the wheelchair and with your equipment records for future reference to obtain replacement parts or additional copies of the operating instructions. To understand BRODA's serial numbering system refer to Appendix 2 in the back of this manual, or call customer service at 1-800-668-0637.

SECTION 1 - SAFETY REQUIREMENTS & DETAILED WARNINGS

This section must be read by all operators of the BRODA wheelchair before they attempt to use the product. It is the caregiver's primary responsibility to ensure that only people who are familiar with the information contained in this manual are authorized to operate or move the wheelchair.

Before operating the chair with the patient in the chair, make sure the patient is properly positioned to maintain patient and caregiver safety, as well as maintaining the maximum stability of the chair.

Caregivers must be prepared to support the weight of the patient in the chair when tilting and returning the occupant of the wheelchair to the full upright position. Always make sure to use proper body mechanics while operating the chair, to avoid injury.

All service and adjustments to the chair should be performed only while the chair is unoccupied.

Only authorized BRODA accessories and parts are to be used on Broda chairs. BRODA is not responsible for injury or damage due to unauthorized parts, or accessories being applied to the BRODA chair.

Immediately after service and adjustments, and before use, always ensure all components of the chair are securely tightened and in proper working order, otherwise damage or injury may occur.

Always determine your safety limits by practicing maneuvers you would perform using the chair, such as bending, leaning, transferring, and reaching, in the presence of a qualified healthcare professional.

Always ensure anti-tippers are attached and adjusted to prevent the wheelchair from tipping over.

Do not lean forward out of the wheelchair any further than the length of the armrests. Make sure the casters are pointing forward when leaning forward. Otherwise, the chair may tip over.

Do not lift the chair by any removable parts. This action may result in damage to the chair, or injury to the user.

Do not attempt to pick up objects on the floor by leaning forward and reaching down between your knees. This may cause the chair to tip forward.

Do not lean backward over the chair back when in a tilt position. Doing so may cause the chair to tip over.

Do not attempt to propel the wheelchair from a tilted position. Otherwise the chair may tip over.

Do not attempt transfers from a tilted position. Otherwise the chair may tip over.

Do not attempt to maneuver or park on slopes greater than 9°. Otherwise the chair may tip over.

Always engage wheel locks before attempting to transfer in or out of the wheelchair. The wheel locks are not brakes and should not be used to stop a moving chair, as the chair may tip over.

Do not attempt to climb or descend slopes greater than 9°, go over curbs or obstacles, operate on roads or streets, or use an escalator to move a wheelchair between floors. Doing so may cause the chair to tip over and cause bodily harm to you, the occupant of the chair, or cause damage to the chair itself.

Do not use the footplates for transfers. Do not stand on the footplates. When performing transfers, or getting in or out of the chair, ensure the footplates are in an upright position.

1.1 Before First Use **WARNING**

BRODA wheelchairs are provided fully assembled and are considered ready to use after purchaser inspection, functional testing, and when all training requirements have been met by qualified caregivers after receipt of wheelchair. If the wheelchair does not appear to be in “ready to use” condition upon receipt, immediately contact your supplier and do not put the wheelchair into service until after your concerns have been resolved.

This manual must be read thoroughly by the caregiver(s) directly responsible for the patient’s nursing care before the wheelchair is put into service. This manual must also be read thoroughly by new caregivers, prior to the first time a new caregiver operates or moves the wheelchair, once the wheelchair has been put into service. The patient’s family members, who share some of the responsibility for the patient’s care, are considered a caregiver only after they have read this manual, received instruction on the wheelchair’s safe use by a professional caregiver, and a caregiver directly responsible for the patient’s care has given their approval.

The wheelchair must be visually inspected for damage, missing parts, and loose fittings (fasteners) prior to first use or testing the wheelchair’s functions. Functional testing must be successfully completed after visual inspection and before first use. These obligations apply both to the first use of the wheelchair and to all subsequent uses.

An in-service on the operation and safety issues, as described in this manual, must be given to the patient’s caregivers prior to its first use.

1.2 Application **WARNING**

The BRODA 587 Manual Wheelchair will be primarily used, but not limited for use by residents in a Nursing Home or institutional setting. The suitability and application of a BRODA wheelchair is to be determined by a professional caregiver who is familiar with the seating needs of the patient using the wheelchair. Any other use of the wheelchair is excluded from possible liability claims, and may void the warranty.

The 587 is not to be used in the shower. Use in the shower will void the warranty.

BRODA does not recommend that the user of this chair be transported in vehicles while in the wheelchair and that appropriate seating in vehicles be provided for the user as made available by the auto industry. BRODA does not recommend or endorse any wheelchair transportation system.

The wheelchairs are not explosion resistant and may only be used where there are no inflammable gases or liquids present such as anesthetics or petroleum based cleaners.

The BRODA 587 wheelchairs are designed for use with specific BRODA accessories and replacement parts. Any use of non-BRODA spare parts or accessories with a BRODA wheelchair is excluded from possible liability claims and voids warranty.

1.3 Legal Restrictions **WARNING**

BRODA wheelchairs may only be used as described in this manual and with proper regard for recognized healthcare and work place safety and accident prevention practices. BRODA wheelchairs may not be operated or used with non-BRODA replacement parts or accessories, which could endanger patients, staff, or other third parties. The wheelchair may only be moved or operated by caregivers or family members who can guarantee its correct operation because they have read and fully understand this manual and the safety issues discussed herein.

1.4 Position of Wheelchair “Danger of Falling” **WARNING**

Immediately after a patient is transferred into a wheelchair, we recommend that the wheelchair's seat be tilted sufficiently to prevent the patient from sliding or falling forward off the wheelchair. The amount of seat tilt used should be determined by the patient's caregiver who is responsible for seating.

We recommend that the patient's feet be correctly positioned on the footrests to prevent the patient from sliding or falling forward off the wheelchair. The amount of elevation used should be determined by the patient's caregiver who is responsible for seating.

1.5 Position of Seat Tilt “Danger of Tipping” **WARNING**

In an attempt to prevent agitated patients from falling out of the wheelchair or tipping the wheelchair forward, the caregiver may decide to tilt the wheelchair. The amount of seat tilt used should be determined by the patient's caregiver who is responsible for seating. Always ensure the patient is properly positioned in the chair before tilting.

Before operating the seat tilt, carefully read through section 1.9 Repositioning of Patient “Danger of Pinching.”

1.6 Propelling and Transferring “Danger of Tipping” **WARNING**

To aid in patient comfort, the caregiver may decide to tilt the wheelchair. We recommend that the wheelchair not be propelled from a tilted position since the wheelchair is prone to tip backwards. Transfers to and from the wheelchair should not be performed from a tilted position because the wheelchair is prone to tip backwards.

The wheelchair should always be in an upright position when propelling and performing transfers. If the wheelchair should tip while occupied, the anti-tippers will prevent it from falling completely.

1.7 Wheelchair Placement “Danger of Tipping” **WARNING**

We recommend that when a patient has been moved to their destination, the wheelchair is placed so the patient cannot reach handrails or other objects, fixed or moveable. This is to prevent the patient from pulling the wheelchair over or pulling themselves off the seating surface, and to prevent the patients from pulling moveable objects onto the wheelchair and on themselves.

We recommend that the wheelchair be used in a supervised area to prevent untrained patients, caregivers, or third parties from unauthorized operation, movement, or unsafe actions such as sitting, standing or leaning on the reclined back, footrest, or the armrests. Individuals should not stand on the seat also. These actions, if not prevented, could put the wheelchair at risk of tipping or may damage the wheelchair.

The seat depth, back height, size and position of the wheels, use of the anti-tippers, as well as custom dimensions or changes relate directly to the stability of the chair. Any adjustments to the above items must only be recommended or performed by an individual qualified to do so.

We recommend that a wheelchair only be used on a level surface to minimize the risk of tipping over.

All BRODA 587's are equipped with anti-tippers which are removable and adjustable. However, they should remain attached to the chair and pointed downward at all times. The anti-tippers can be pointed upward if necessary for traveling over a curb or such, however then must be returned to the standard downward position for standard traveling and when the chair is in a stationary position.

1.8 Locking Wheels “Danger of Falling” **WARNING**

The wheel locks must always be applied when:

- The wheelchair is not in use.
- A patient is being transferred (moved) into or out of the wheelchair.
- The patient in the wheelchair is not being moved by a caregiver.

It is important to note that if the wheel locks are applied while the patient is in the chair, that the caregiver does not leave the patient unattended, especially those patients who have the capability or tendency to propel the chair on their own, and/or those who may be agitated. This could cause harm to the patient if they attempt to propel the chair while the wheel locks are applied.

Failure to follow these instructions will unnecessarily increase the risk of serious falls by patients, caregivers, or third parties caused by the wheelchair unintentionally moving.

1.9 Re-Positioning of Patient “Danger of Pinching” **WARNING**

BRODA wheelchairs offer the benefits of seat tilt, footrest, and adjustable, removable arms. During the movement of any of these functions, the following safety measures must be observed:

- The patient's arms must be securely positioned inside the wheelchair frame with their hands on their body.
- The patient's feet must be correctly positioned on the footrests.
- All of the wheelchair's wheel locks have been applied.
- Only one caregiver at a time attempts to operate the wheelchair's functions.
- Only one wheelchair function is operated at a time.
- The patient's and caregiver's body are clear of all pinch points before operating any of the chair functions

Failure to follow these safety measures can put the patient's or caregiver's limbs at risk of injury. Patients who may be unaware of their body position or unable to maintain a safe body position have the highest risk of injury from pinching and caregivers should be more cautious with these patients. A second caregiver may be required to ensure the safety of these patients during these operations.

1.10 Accidental Motion “Danger of Falling or Collision” **WARNING**

We recommend BRODA wheelchairs for indoor use within a long-term care institution and where there is insufficient slope to cause the wheelchairs to move unaided. Wheelchairs used where the

surface is uneven or sloped are at risk of unintended movement and could become a serious danger to the patient, caregiver(s), or a third party. We recommend that BRODA wheelchairs are located away from stairwells, elevators, and exterior doorways. Placing the patient near handrails, tables or stationary objects while the wheel locks are in place should be done with caution and should be supervised. Failure to do so may lead to unnecessary injury due to the patient grabbing hold of the object and either pulling the object on top of them, or causing the chair to tip over.

1.11 Improper Restraint Use “Risk of Serious Injury” **WARNING**

We recommend that alternatives to physical restraints be used with patients while seated in the wheelchair except under the specific instructions of the patient’s primary caregiver and with permission of the patient’s family or guardian. Physical restraints have been identified as a common cause of serious injury to patients while they are seated. We recommend that the primary caregiver responsible for seating first considers the re-positioning options available in the wheelchair to reduce the risks of sliding, falling, or self injury.

If a physical restraint is determined to be appropriate to prevent sliding or falling out of the wheelchair, BRODA supplies both seat belts and thigh belts. In all cases, it is the patient’s primary caregiver who must take responsibility for the safety of the patient if restraints are used.

1.12 Improper Use **WARNING**

The improper use of the wheelchair can be dangerous to the patient, caregiver, or a third party through:

- Unauthorized operation of the wheelchair’s functions.
- Unauthorized movement of the wheelchair.
- Inappropriate use of the wheelchair by a patient who has not been assessed by the caregiver responsible for their seating.
- Attempted simultaneous operation of multiple wheelchair functions by one or more caregivers.
- Attempting to move the wheelchair with the wheel lock(s) applied.
- Applying wheel lock(s) while wheelchair is in motion
- Leaving the patient unattended in the wheelchair near other objects.
- Leaving a potentially agitated patient in an unsupervised area.
- Leaving a patient in a wheelchair on a sloping surface.
- Leaving a wheelchair unattended on a sloping surface.
- Leaving wheelchair unattended without setting wheel locks.
- Transferring a patient in or out of the wheelchair without setting wheel locks.
- Using non-BRODA accessories on the wheelchair.
- Using the BRODA wheelchair at temperatures below 0° Celsius (32° Fahrenheit)

1.13 Cleaning **WARNING**

We recommend the wheelchair be wiped clean with soap and water. A dilute household strength ammonia or chlorine based cleaner may be used if necessary. BRODA wheelchairs should not be cleaned with petroleum based cleaners and any petroleum based products that come in contact with any vinyl surface should be removed as quickly as possible. Petroleum based products make vinyl brittle and will damage the seating surface. Metal parts should be wiped dry after cleaning. The spandex seat and back coverings are to be washed in cold water with small amounts of detergent. Do not wring out. Hang to dry on a hanger covered by a towel.

1.14 Preventative Maintenance **WARNING**

The maintenance on a BRODA wheelchair will vary with the amount of use and the condition of the patient using the wheelchair. We recommend regular visual inspection for signs of wear, damage, loose or missing fittings, and other safety concerns. Also, periodic testing of the wheelchair's functions is appropriate. If a breakage, defect, or operational problem is detected, the wheelchair must be repaired, inspected and tested for function before it is returned to service. For regular use, the wheelchair should be inspected and tested on a bimonthly basis. The wheelchair should be inspected and tested as often as each use if the wheelchair is used:

- By aggressive or agitated patients.
- By patients who have involuntary movement.
- On irregular or sloped surfaces.
- By any unauthorized person.

Do not use any lubricants that contain solvents. Solvents will damage many of the moving components in the wheelchair. If necessary a white, food grade grease (lubricant) may be used on the sliding components in the wheelchair. Do not use spray lubricants as they contain solvents.

Inspection

We recommend regular visual inspection of signs of wear, damage, loose or missing fittings, and other safety concerns. If a breakage, defect, or operational problem is detected, the chair must be repaired inspected and tested for function before it is returned to service.

We recommend that the wheelchair should be inspected as often as each use, if there is any reason to be concerned about the possibility of increased wear or loose or missing fittings. At a minimum, in regular use, the chair should be inspected on a bimonthly basis. The visual inspection procedure should include at least the observation of the following fasteners:

- The bolts and nuts, which attach the rear wheels to the wheelchair base.
- The bolts and nuts, which attach the front casters to the wheelchair base.
- The bolts and nuts, which attach the cylinders that position the seat tilt
- The bolts and nuts, which attach the wheelchair back to the wheelchair seat.
- The bolts and nuts, which attach the wheelchair seat to the wheelchair base.
- The bolts and nuts, which attach the wheel-locks to the wheelchair base.

In addition, the visual inspection procedure should include the observation of the following parts:

- The 2 cylinders that position seat tilt.
- The vinyl straps used in the seat, and back.
- The upholstery.
- The handles and cables.

We also recommend the visual inspection procedure include the observation of any installed accessories.

Functional Testing

We recommend that the wheelchair operation be tested when unoccupied. The testing may be as often as each use if there is any reason to be concerned about the possibility of above normal wear or damage to the chair's components.

If the caregiver performing the functional testing believes that any function is not operating correctly, the chair should be taken out of service until a satisfactory functional test can be completed.

The caregiver performing the testing should be aware that the seat tilt operations will be more difficult when the wheelchair is unoccupied.

When performing repairs or maintenance, do not use any lubricants that contain solvents. Solvents will damage many of the moving components in the chair. If necessary, a white, food grade grease lubricant may be used on the sliding components on the wheelchair. Do not use spray lubricants on any part of the chair.

1.15 Patient Specific Instructions **WARNING**

The professional caregiver responsible for the patient's seating shall add such additional instructions as are necessary for the safety and comfort of the patient using the wheelchair based on their professional experience and knowledge of the patient's specific conditions and requirements. These instructions form a part of the Safety Requirements for using the wheelchair with that patient and must be made available to all caregivers.

Safety and Handling of Wheelchairs

This manual describes the most common procedures and techniques involved in the safe handling and maintenance of BRODA chairs. It is important to understand, both conceptually and physically, the handling of the chair in order to prevent any injury to body, or misuse of the chair. The information provided here is to be regarded as a general guide and is based on techniques that have proven to be beneficial and successful by many users.

Stability and Balance

Any activities that require movement in the wheelchair have an effect on the center of gravity of the chair. Therefore, it is very important not to lean forward out of the chair any further than the length of the armrests. Also, do not attempt to reach for objects on the floor by moving forward in your seat, or leaning over between the knees to pick them up.

If you do need to lean forward, ensure that the front casters are pointing forward to maintain the stability of the chair. You can do this by pushing forward and then reversing it in a straight line. It is advisable to also engage the wheel locks when leaning forward.

Leaning over the top of the back upholstery will change your center of gravity and may cause the chair to tip over. It is advisable to position the chair as close as possible to the desired object, then point the front casters forward. Reach back only as far as your arm will extend without changing your sitting position.

When attempting a transfer in or out of the wheelchair, reduce the distance of the gap between the chair and the destination of the transfer. Ensure the casters are turned parallel to the object you are transferring onto, and that the wheel locks are engaged. It is recommended that you practice bending, reaching and transferring activities with the help of a qualified healthcare professional before attempting such activities on your own. This will familiarize yourself and your caregiver with the particular safety limits of the chair.

It is important that if assistance is required with the use of the chair, that the caregiver remember to bend their knees, and keep their back straight whenever tipping the chair, or pushing the chair over curbs or other obstacles.

Lifting the chair by any removable or detachable parts may result in injury to the user, and will cause damage to the chair. Check for any signs of loose fittings periodically to ensure parts are secure. If parts are not secure, contact a qualified technician to assess, and fix, the chair before further use. Using the detachable parts to move the chair or as lift supports is inadvisable, as they may be inadvertently released causing possible injury or damage to the chair.

Tipping the Chair

Never tip the wheelchair without assistance. When tipping the chair, the assistant should grasp the back of the chair on a non-removable part, informing the occupant of the chair as to what is about to happen and to lean back. It is important that the patient's feet and hands are clear of all pinch points and wheels.

For curbs, short stairs and other small obstacles, place your foot on the crossbar of the frame base and begin to tilt the wheelchair toward you. Push down in a continuous motion until a balance point is reached and until the front casters clear the obstacle. When lowering the chair, do not let the wheelchair drop the last few inches as this could cause an injury, or damage to the chair. Roll the wheelchair forward and slowly lower the front of the chair in a smooth, continuous motion. Push the wheelchair forward until the rear wheels roll up and over the obstacle. The assistant may be required to slightly lift the chair to help get the rear wheels over the obstruction. If the anti tippers are repositioned upward during this operation, be sure to return them to their proper downward setting immediately after this operation.

Stairways

BRODA does not recommend that the occupant be seated in the chair when moving the chair between floors when no elevator is available. If there is no other option, two assistants are required. With one assistant behind the chair, tilt the chair back to the balance point and back the chair up against the first step.

A second assistant, with a firm grasp on a non-detachable part of the frame, should lift the chair up and over the stair, steadying the chair as the first assistant places one foot on the next step and repeats the process.

Never use an escalator to move a wheelchair between floors.

SECTION 2 - DEFINITIONS AND TECHNICAL INFORMATION

2.1 Definitions

“BRODA” means BRODA Enterprises Inc. doing business as BRODA Seating. “Wheelchair” refers to BRODA Model 587 Manual Wheelchair.

“Long-Term Care Institution” refers to a Nursing Home, Hospital, or other Health Care facility that provides health and personal care to its residents on a long-term basis.

“Patient” refers to an individual using the wheelchair who may be limited to a sitting position.

“Professional Caregiver” refers to the Doctors, Nurses, Therapists, Nurses Aids, Health Care Aids, and other Specialists who provide health and personal care to its residents.

“Caregiver” refers to any person who is appropriately trained to provide care or services to the patient or the wheelchair used by the patient and may include the patient’s family members or guardian.

“Seat Tilt” refers to changing the angle of the wheelchair’s seat with respect to the wheelchair frame (or ground), without changing the angle between the back and the seat.

“Transfer(s)” refers to the movement of a resident into or out of a wheelchair with the assistance of their caregiver(s).

“Mechanical Transfer(s)” refers to the movement of a patient into or out of a wheelchair with the assistance of their caregiver(s) using a patient lift or other assistive device that bears the weight of the patient.

“Safety Requirements” are the important information contained in Section 1 which must be followed to ensure the safe operation of the wheelchair for the patient, caregivers, and third parties.

2.2 Technical Information

Wheelchair Frame

The frame is constructed of 16 gauge tubular steel. The base, seat, back, arms and footrest are powder-coated for durability and corrosion resistance. Recommended maximum patient weight is 250 lbs (114 kg) for wheelchair widths up to and including 20”.

Adjustments to the seat tilt function is supported by a mechanical locking device designed to permit controlled movement during the operation of these functions. No motors or other powered devices are used in the wheelchair.

Casters and Wheels

The front casters are 6” swivel with non-marking rubber tires. The rear mount standard 22” mag wheels are used for patients to propel themselves. Minimal maintenance is required for both casters and mag wheels, except for in extreme conditions as steam cleaning, pressure washing or autoclaving.

Side Panels

Removable side panels provide lateral support and containment of the patient while sitting in the wheelchair.

Disinfection

For normal cleaning we recommend the wheelchair be wiped clean with soap and water. When necessary, a household strength diluted ammonia or chlorine based cleaner may be used. BRODA chairs should not be cleaned with petroleum base cleaners. Any petroleum based products that come in contact with any vinyl surface should be removed as quickly as possible. Such products will make the vinyl brittle and will damage the seating surface and cushions. Metal parts and cushions should be wiped dry after cleaning. Seat and back covers are to be washed in cold water with small amounts of detergent. Do not wring out. Hang to dry on a hanger covered by a towel.

2.3 Shipping and Storage Specifications

BRODA wheelchairs should be shipped and stored in an upright condition and not stacked higher than 3 boxes. No other materials should be shipped or stored on top of a BRODA box. BRODA boxes should not be placed on pallets.

BRODA wheelchairs should be shipped and stored at temperatures between minus 20 degrees Celsius and plus 40 degrees Celsius. BRODA wheelchairs should not be used until they are between 0 degrees Celsius and 30 degrees Celsius. BRODA wheelchairs should be kept in a clean, dry environment.

On receipt, we recommend that the shipping carton be immediately examined for damage. Any damage should be noted on the delivery receipt and a request for inspection by the transportation company should be made. The shipping carton should be opened immediately and the wheelchair examined for concealed shipping damage. If the wheelchair appears to be damaged, contact the customer service department at BRODA Seating.

2.4 Label Locations



**SEAT TILT
Squeeze Handle**

Warning Stickers (Yellow)

WARNING

Propel only from a fully upright seated position
Do not lean over edge of the wheelchair
Operate only on level surfaces

WARNING

DO NOT OPERATE WITHOUT
THE ANTI-TIP TUBES
INSTALLED

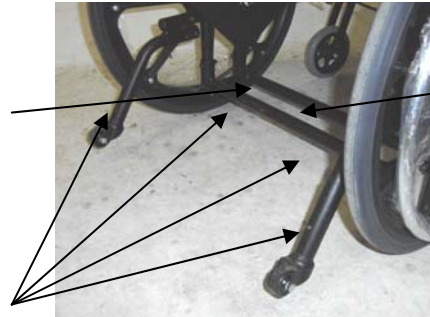

Weight Capacity Sticker

WEIGHT CAPACITY
250 LBS. (114 kgs.)
REFER TO OWNER'S MANUAL



Serial Number Label (Silver)

BRODA SEATING
1-800-668-0637
PRODUCT #
SERIAL #
MADE IN CANADA

BRODA

MADE IN CANADA / FABRIQUE AU CANADA

385 Phillip St., Waterloo, ON, Canada, N2L 5R8
PHONE 1-519-746-8080 FAX 1-519-746-8616

SECTION 3 - CAREGIVER MANAGEMENT

BRODA's unique and innovative wheelchairs provide the optimum in re-positioning functions and mobility. However, BRODA's products were designed to be recommended by professional caregivers. The maximum benefit to the patient using this wheelchair will be achieved with the advice and assistance of their caregivers.

At the customer's request, the initial basic training of the patient's caregiver(s) will be provided by either the local BRODA representative who supplies the wheelchair or the HME Provider. The caregiver(s) must adhere to the Safety Requirements at all times to ensure the safety of the patient, caregivers, and third parties.

The customer will maintain a list of caregivers who have read this manual and are authorized by them to operate and move the wheelchair.

WARNING BRODA assumes no liability for damage, injury or accidents caused by careless, negligent, incorrect, or unauthorized operation or movement of its wheelchairs. It is the responsibility of the caregiver to ensure the patient is secure in the chair and that the proper degree of care is given based on the patients needs.

SECTION 4 - WHEELCHAIR OPERATION

4.1 Armrests

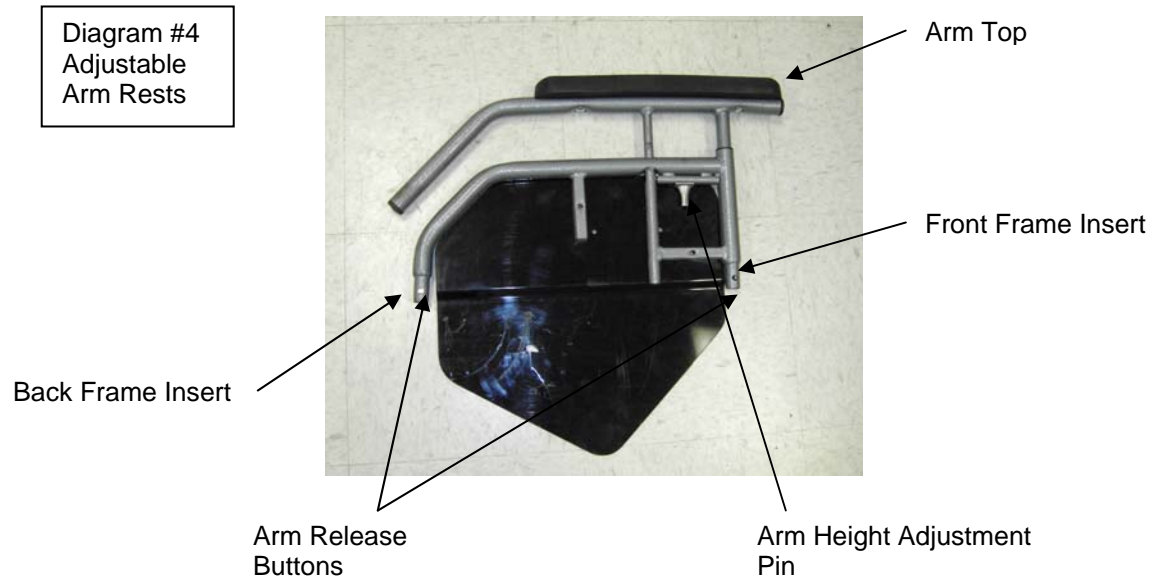

Removing & Installing the Armrests

1. Press in front Arm Release Button.
2. Once Arm Release button is engaged, remove Front Frame Insert by swinging arm up. Once Front Frame Insert is removed, removed Back Frame Insert by pressing in rear Arm Release Button.
3. To reinstall, push in rear Arm Release Button and insert Back Frame Insert into frame just behind the rear mag wheel.
4. Push in front Arm Release Button and insert Front Frame Insert into frame

Adjusting the Armrest Height

1. Depress the Arm Height Adjustment Pin toward the front of the chair
2. Pull up on the arm top to your desired height. Release the pin and push down until the pin locks with the tube holes.
Note: Do not place fingers directly under arm as this can cause pinching.



Replacing the Armrest Tops

1. Using a Phillips screwdriver loosen the 2 screws under arm top.
2. Remove Arm Top and place new Arm Top on frame and using same screwdriver and screw new Arm Tops in place.

Depressing
Arm Pin

4.2 Anti-Tippers and Wheel Locks

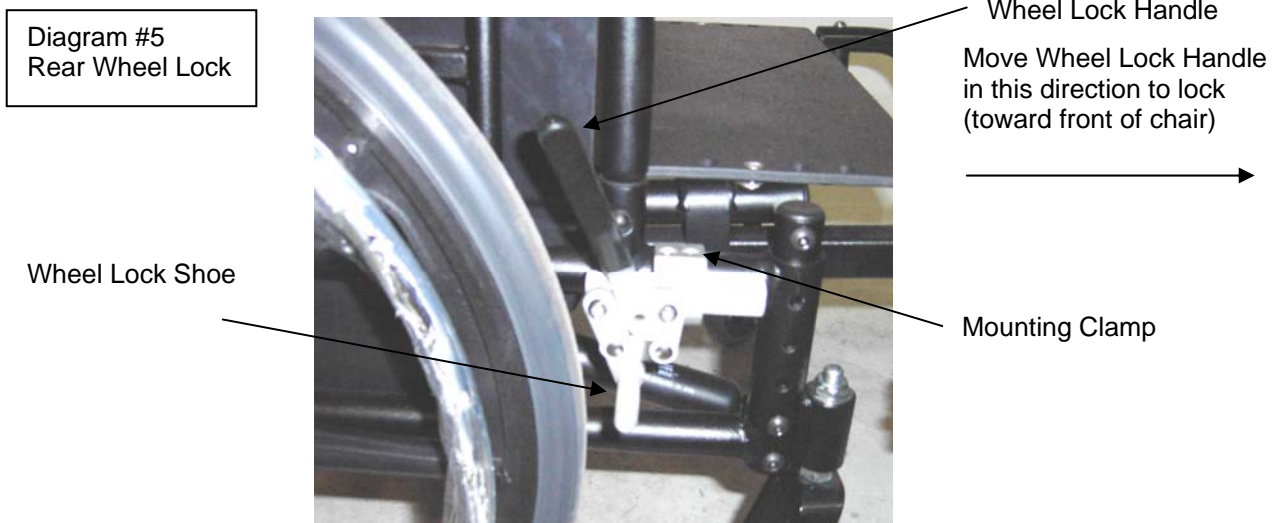

Locking/Unlocking the Rear Wheels

1. To lock push Wheel Lock Handle towards the front of the wheelchair until wheel is locked in place.
2. To unlock pull Wheel Lock Handle upwards towards the back of the wheelchair. It rests perpendicular to the ground.

Adjusting the Wheel Lock

1. Ensure wheel lock is unlocked.
2. Using a 5 mm Allen key wrench, loosen the 2 socket head bolts on top of the mounting clamp.
3. Once loose, slide Locking Unit to desired position and tighten.
4. Engage lock and measure the distance the wheel lock is embedded into the tire. When engaged, the wheel lock must be embedded in the tire at least 1/8" to hold the wheelchair.
5. Repeat steps 1 through 4 if necessary until the 1/8" measurement is obtained.

Anti-Tippers

Diagram #6
Anti-Tippers

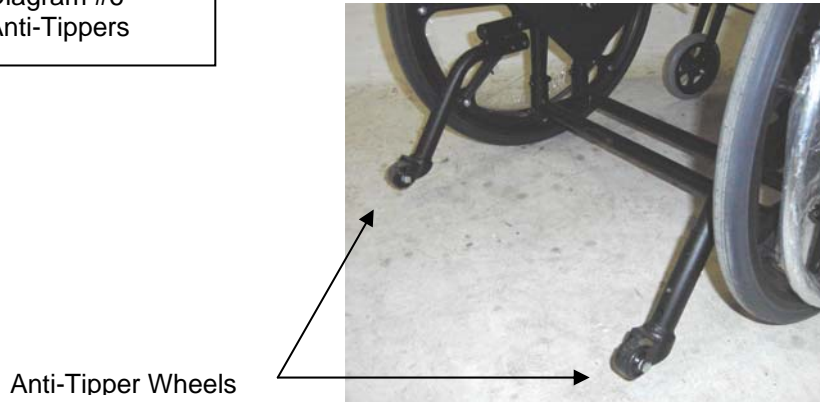

1. All BRODA 587's are equipped with anti-tippers which are removable and adjustable. However, they should remain attached to the chair and pointed downward at all times and adjusted to the longest possible setting. The anti-tippers can be pointed upward if necessary for traveling over a curb or such, however then must be returned to the standard downward position for standard traveling and when the chair is in a stationary position.

4.3 Seat and Back

Tilt Feature

Diagram #7
Tilt Feature



Standard Positioning



Full Tilt 45°

Adjusting Seat Tilt

1. With the patient in the wheelchair, press the tilt handle which is located directly underneath the right hand grip at back of the wheelchair.

2. Push downward on the hand grips at back of wheelchair while pressing the tilt handle (patient weight will dictate the amount of assistance that is required). The amount of tilt used should be determined by the patient's caregiver who is responsible for seating.
3. Release handle when the desired degree of tilt is obtained.
4. To return the patient to the default seat tilt position, engage the tilt handle and lift up until seat stops

Adjusting Backrest Angle

1. Remove bolt on adjustable plate.
2. Reposition backrest angle to 90°, 95°, 100°, 105°.

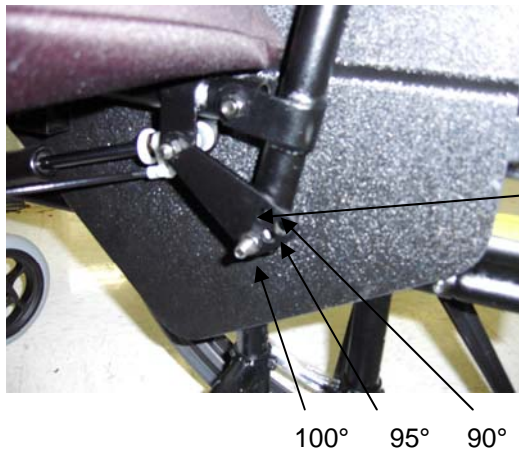

Diagram #8
Backrest Adjustment
Plate

3. Reinstall bolt in appropriate hole on adjustable plate.

4.4 Accessories

Installing the IV Pole (Option)

Diagram #9
IV Pole

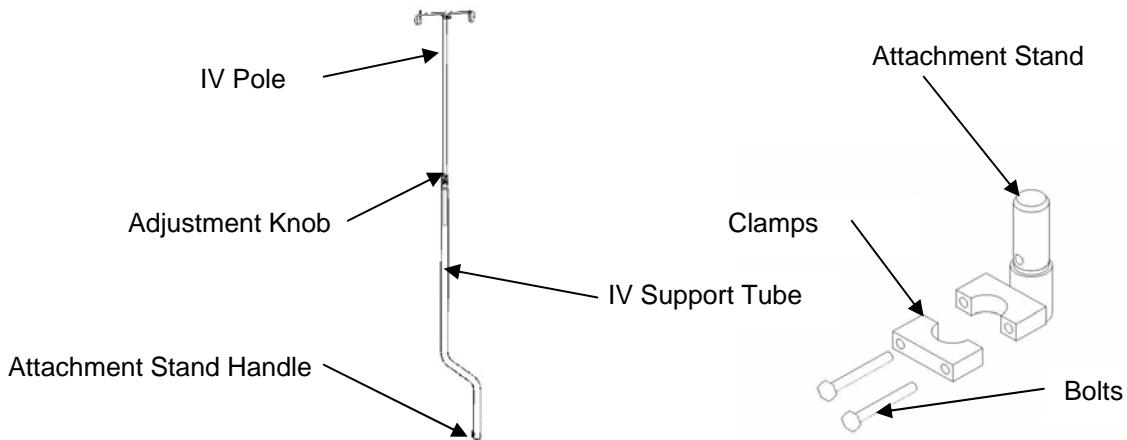

1. Turn the Attachment Tube Handle at the bottom of the pole to loosen and release the clamp so that the clamps can be attached to the base frame.
2. To attach the clamp to the wheelchair, remove the bolts from the clamp, so it is in two pieces, and fit it to the wheelchair frame.
3. Place clamps around the designated location on the wheelchair frame, with the Attachment Stand to the back of the frame.
4. Using two 7/16" wrenches tighten the bolts that will secure the clamps around the wheelchair frame.
5. Once secured, the IV pole is attached by fitting it back over the Attachment Stand, and tightened by turning the handle.

4.5 Adjustable Headrest

The headrest for the 587 is very versatile in its adjustability, allowing for a wide variety of needs to be met. It can be adjusted in height, depth, yaw, pitch and lateral positioning.

The headrest requires a 3/16" Hex (Allen) Key for adjustability. A 3 mm Hex (Allen) Key must be used for the ball joint.

NOTE: After adjusting headrest to it's desired position, always ensure it is secured in place.



Diagram #10
Rear View

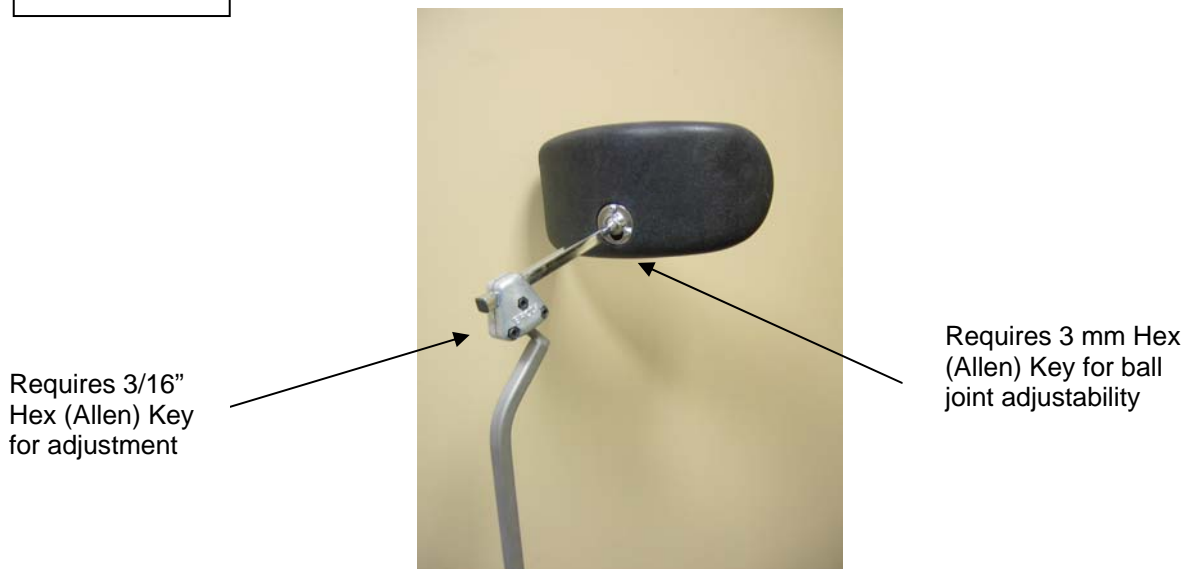

Attaching Headrest

1. Insert the vertical post into the mounting tube
2. Place the headrest at the desired height and turn the handle until it is tight and the headrest is secure.

4.6 Solid Seat Pan and Drop Seat and Back

Broda Seating has developed the 587 V2 to accommodate a
587 has the versatility of using other manufacturers' seats and backs

Diagram #15
Solid Seat Pan



Installing Seat Pan

1. Remove strapped seat if applicable. (To Remove strapped seat, detach the four bolts that attach the seat to the frame and lift seat off frame)
2. Place seat pan on seat frame in the position of desired seat depth of 16", 17", 18", 19" or 20".
3. Secure seat pan to frame by inserting all four bolts each in the appropriate corresponding holes in the seat pan and attaching to frame.
4. Tighten bolts

To Remove: Reverse Installation instructions

Installing Drop Seat

1. Remove the strapped seat or seat pan if applicable. (To remove strapped seat or seat pan, Detach the 4 bolts that attach the seat to the frame and lift seat off frame)
2. Place seat in position over the seat frame, as per manufacturers instructions.

Installing Drop Back

1. Remove the strapped back if applicable. (To remove strapped back, detach the bolts that Attach the back to the frame, and remove back)
2. Place the Back on the frame on the chair.
3. Install as per manufacturers instructions.

4.7 Seat Height Adjustment

The seat height on the 587 can be adjusted from 14" to 20" in one inch increments with the solid seat pan and 15" to 21" with the strapped seat. The desired seat height can be achieved by adjusting the seat height posts, caster and mag wheel sizes and mounting positions. Below is a diagram that outlines the various seat height combinations:

Note: To achieve the lowest seat height (14" for seat pan, 15" for strapped seat) an extra hole must be drilled in the caster fork (can be done in the factory or in the field) or a drop seat must be used.

587 Seat Height Combinations

Seat Height Post Adjustment Range (With Seat Pan) (For Strapped Seat Add 1")	Mag Wheel	Mag Wheel	Caster Option 1		Caster Option 2	
	Diameter	Mnt Position	Diameter	Fork Position	Diameter	Fork Position
14", 15", 16", 17"	20"	Mid	6"	High	None	None
15", 16", 17", 18"	20"	High	6"	Mid	8"	High
14", 15", 16", 17"	22"	Low	6"	High	None	None
15", 16", 17", 18"	22"	Mid	6"	Mid	8"	High
16", 17", 18", 19"	22"	High	6"	Low	8"	Mid
15", 16", 17", 18"	24"	Low	6"	Mid	8"	High
16", 17", 18", 19"	24"	Mid	6"	Low	8"	Mid
17", 18", 19", 20"	24"	High	None	None	8"	Low

Seat Height Post Adjustment:

- 1) Locate the seat height adjustment bolts on both sides of the front of the seat on the chair frame
- 2) Using a 3/16" Allen key wrench to the outside of the frame and a 1/2" wrench to the inside of the frame, remove the bolts. Be sure to note the location of the bolts and spacers.
- 3) Raise or lower the seat by changing the cylinder mounting position to correspond with the holes at the desired seat height. (See the seat height combination diagram to determine the desired seat)
- 4) Insert the bolts through the desired corresponding holes and tighten the bolts.
- 5) Adjust the caster height position and mag wheel position accordingly if necessary. (See the seat height combination diagram, page 24)

Diagram #16
Seat height post adjustment

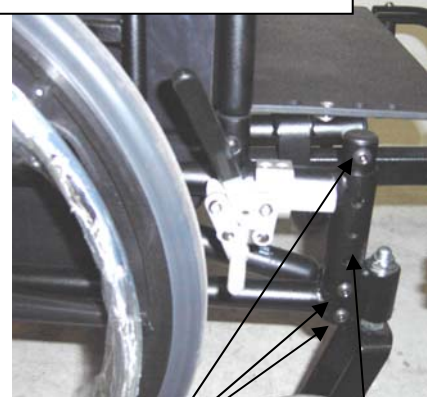

Seat height adjustment bolts (at front of frame)

Seat height increments

Diagram #17
Raised seat
height



Raised seat height

Caster Height Adjustment:

- 1) Locate the three caster fork adjustment positions on the front casters,
- 2) Using a ½” wrench, remove the hex screw and locknut that secure the caster to the fork.
- 3) Raise or lower the caster to the desired position (See the seat Height combination diagram to determine the desired position)
- 4) Insert the hex screw and locknut through the corresponding holes and tighten the bolts.



Diagram #18
Caster fork positions

Mag Wheel Height Adjustment:

See section 5.4 for instructions on mag wheel installation and removal. See the seat height combination diagram under section 4.7 to determine the mag wheel mounting position.

4.8 Seat Depth Adjustment

The 587 offers two style seats, a strapped seat or a solid seat pan. The strapped seat is available in depths of 15.5”, 17” (standard), 18.5” and 20”. The solid seat pan is available in depths of 16” – 20” (17” standard) in one inch increments. All dimensions are approximate.

Note: For a depth of 20” with a strapped back, a larger seat pan must be used. For depths of 19” and 20”, with a non strapped back, a larger seat pan must be used

Seat Depth Extension for Strapped Seat

- 1) Remove the front strap from the seat by cutting the strap and drilling out the rivets that hold it in place with a 3/16” drill.

- 2) Remove the two seat plugs from the front of the seat frame (one on each side of the seat).
- 3) Install the two new seat extension plugs and secure them to the seat frame with the ¼" x 1 ¼" fasteners applied. Make sure the rivet holes on the seat extension plug are on the outside when the plugs are installed.
- 4) Install new straps on seat extension plugs. Refer to strap installation instructions on page 33.
- 5) Adjust the length of the footrest bracket according to the seat depth.

Footrest Bracket Length Adjustment for Seat Depth Extensions

- 1) Locate the footrest bracket extension rail bolts on both sides of the chair frame.
- 2) Using a 3/16" Allen key wrench to the outside of the frame and a ½" wrench to the inside of the frame, remove the bolts
- 3) Adjust the extension rail to the desired position and reinsert the bolts in the appropriate holes through the seat frame. Tighten bolts.

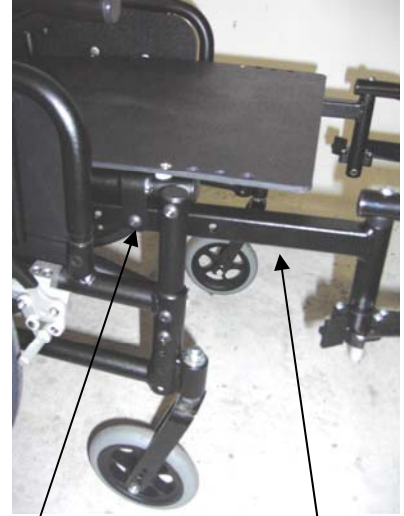

Adjustment bolts

Diagram #19
Footrest bracket
extension rail

Seat Depth Extension for Solid Seat Pan

- 1) Locate the 4 seat pan adjustment bolts that attach the seat pan to the frame
- 2) Using a Phillips screwdriver, remove the bolts and adjust the seat pan to the desired seat depth.
- 3) Reinsert the bolts in the appropriate corresponding holes and tighten the bolts
- 4) For seat depths of 20" or greater with a strapped back, (19" or 20" with a non strapped back) a larger seat pan must be used.
- 5) Adjust the footrest bracket length to accommodate the seat depth (See instructions above)

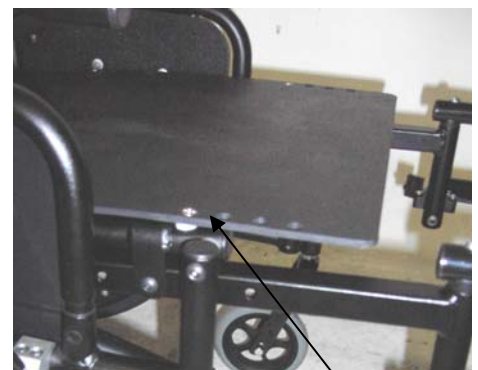

Diagram #20
Seat pan
adjustment bolt

SECTION 5 - WHEELCHAIR REPAIR AND MAINTENANCE

5.1 Suggested Tool Kit

A variety of fasteners are used in the assembly of BRODA's products. The majority of these are 1/4" or 5/16" diameter bolts and nuts requiring 7/16" and 1/2" wrenches. However, some of the individual component fasteners may be metric.

Listed below are the most common tools used in the assembly of our wheelchairs, from time to time you may be required to do repairs or modifications in the field. Therefore we suggest obtaining the following items to make your job easier.

Qty.	Item	Where Used
2	7/16" combination wrench	Nuts & bolts used to secure wheel lock mounting bar to base
2	1/2" combination wrench	Nuts & bolts used to pivot seat and back, as well as gas cylinders
1	17mm combination wrench	Lock nut on the stem of the gas cylinders and nut used to fasten the caster fork
1	3/16" Allen key	Bolts on seat height adjustment post and seat rails
1	5 mm Allen key	Lock nut on mounting clamp of mag wheel
1	1/4" Allen key	Headrest adjustment
2	5/8" combination wrench	Mag wheel axle
1	Phillips screwdriver	Screws used to secure armrests and cable handles
1	Heat gun	Use for heating vinyl straps during strap replacement or reversal
1	Hand Rivet Gun	Used for installing of vinyl straps

5.2 List of Commonly Replaced Parts

Part No.	Description
ACS A-3	Black urethane plastic armrests
PRT-CABHAND	Control cable and handle for gas cylinder release mechanism
PRT-CABLEACT	Actuator for gas cylinder release mechanism
PRT-CABLERELEAS	Complete release mechanism for gas cylinders consisting of the prt-cable, prt-cableact, and prt-cablereleas
CASTERS 6"	6 " front casters
REAR WHEELS	22" Rear Mag Wheels
PRT-PAB7	800N Locking gas cylinder with a 8" long body
PRT-STRAP	Vinyl straps used on wheelchairs. You must specify the color, seat width of the wheelchair, and location of the strap on the wheelchair when ordering.

Note: Please include the model number and serial number of the wheelchair whenever you are ordering parts. These can be found on a sticker that is attached to the cross member on the bottom of the chair.

NOTE: Only a person with training on the BRODA chair should attempt to do any repairs or maintenance on the wheelchair. Certain repairs may require a BRODA representative to personally attend to the repair. If you are unsure as to what is required, call BRODA customer service at 1-800-668-0637.

5.3 Cables and Cable Handles

Diagram #21
Cable and Handle

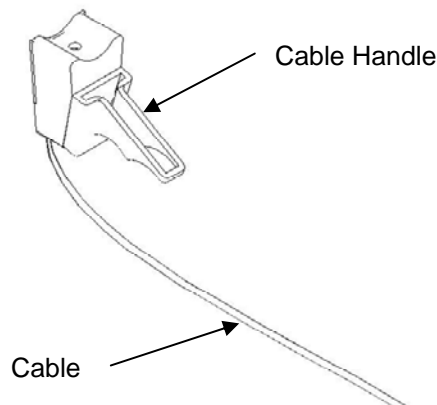

Maintaining the Cables and Cable Handles

The cables and cable handles do not require any maintenance. Both replacement pieces are shipped out together fully assembled.

Removing and Installing the Cables and Cable Handles

The cable is used in conjunction with a cable handle and an actuator to control the function of the gas cylinder. The cable is held in place on the handle end by a cable housing retaining clip. On the actuator end the cable hooks into the lever that depresses the control pin on the cylinder and the cable housing clip into the actuator housing.

1. Unclip the cable from the actuator on the cylinder.
2. Cut the cable ties that secure the cable to the frame of the wheelchair (carefully note the location of the cable ties and how the cable is threaded around the frame of the wheelchair.)
3. Unscrew the handle from frame using a Phillips screwdriver
4. Remount the new handle assembly to the frame of the wheelchair using the screw removed in step 3.
5. Feed the new cable around the frame of the wheelchair the same as the previous one and install new cable ties where necessary.

- Hook the end of the cable into the lever in the actuator and clip the cable housing into the actuator housing.

5.4 Rear Wheels

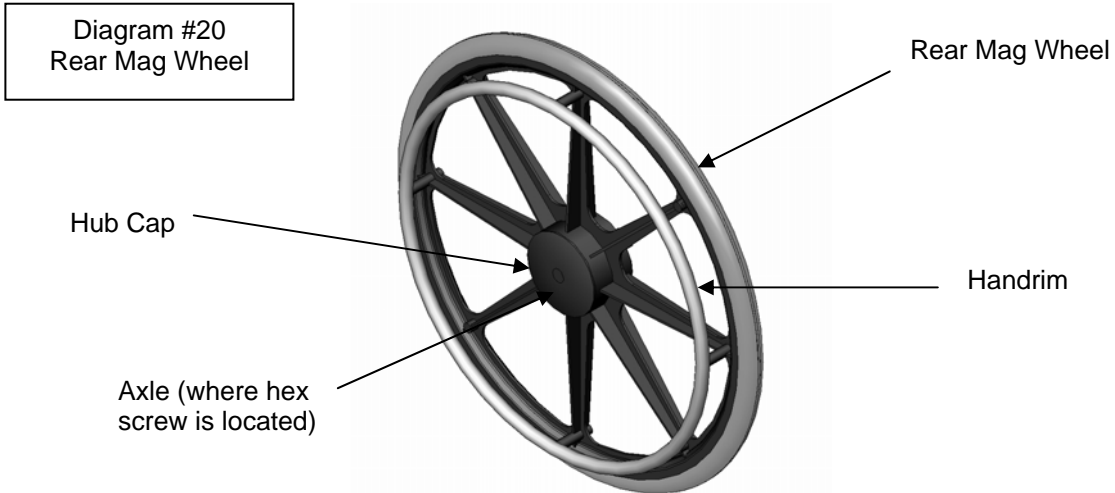

Removing and Installing the Rear Mag Wheels

- Remove hubcap from wheel by turning counter clock-wise by hand
- Using a 5/8" combination wrench, loosen hex screw and locknut at axle of wheel
- To install, reverse steps 1-2.
Ensure that the head of the bolt is towards the inside and the nut is on the outside

Note: The rear mag wheels can be mounted in 3 vertical positions on the mounting plate: low, mid and high. Refer to the seat height combination chart on page 24 to determine the appropriate mounting position for the wheel.

The rear mag wheel can also be mounted horizontally along the base on the side rail.

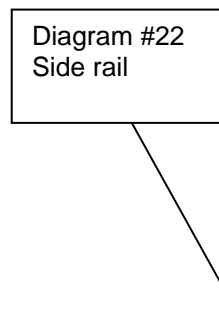
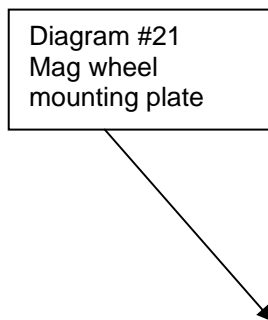



Replacing the Rear Wheel Hand Rim

1. Remove rear wheel(s) from wheelchair (see Removing/Installing the Rear Wheels)
2. Remove the mounting screws from the inside of the wheel using a Phillips screwdriver
3. Remove existing hand rim
4. Install new hand rim by reversing above steps
5. Reinstall rear wheel (see Removing/Installing the Rear Wheels section for instructions)

Installing/Replacing Fork Assemblies

Diagram # 21
Front Caster

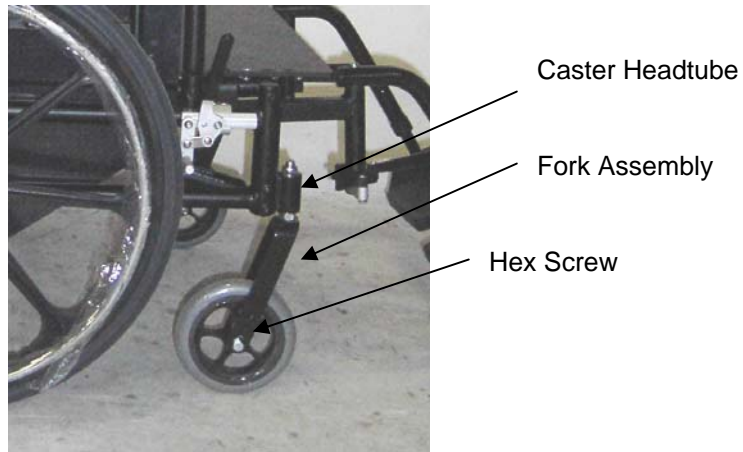

1. Using a 17mm wrench remove the locknut securing the fork to the caster headtube
2. Remove front caster from caster headtube
3. Slide in new fork assembly
4. Reverse Steps 1-3 for reassembly

Replacing Front Caster in Forks

See instructions for caster height adjustment in section 4.7 Seat Height Adjustment

5.5 Gas Cylinders

Diagram #22
Gas Cylinder

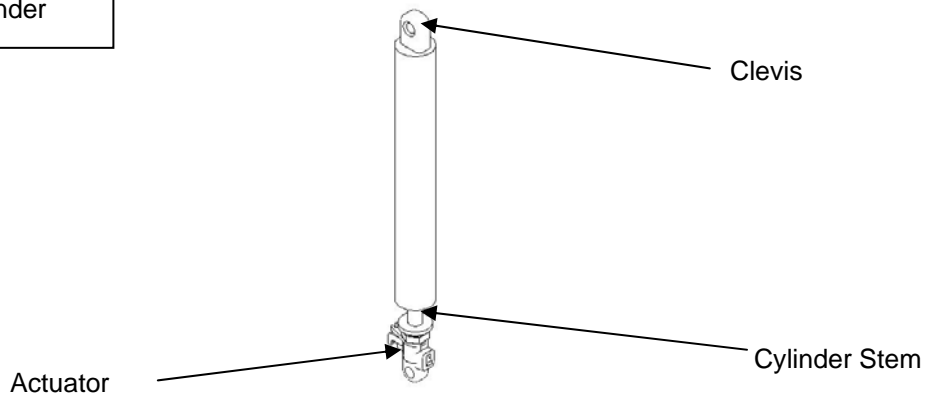

The use of gas charged springs on BRODA products allow the caregiver to easily make adjustments to the tilt and recline with a minimum amount of effort. The gas cylinders contain pressurized Nitrogen gas, it is not flammable nor is it toxic. The cylinders provide 800 Newtons (180 lbs) of force. In other words, the cylinders provide assistance and reduce the amount of weight the care giver has to lift.

Part No.	Description	Where Used
Part No. PRT-PAB7	350N locking gas cylinder with a 10" long body	Used for the seat tilt

How do they work?

On the end of the stem of the cylinder is a small pin. When the operator depresses the handle this pulls on the cable which in turn pulls on a small lever inside the actuator mechanism into which the stem of the cylinder is mounted. This depresses the pin which opens a valve located inside the barrel of the cylinder, allowing for changes in position. When the operator releases the handle, the valve closes and locks the cylinder in the desired position.

The function of the actuator is to push against the pin and open the valve that controls the cylinder. If the actuator is not properly adjusted when mounted on the cylinder, problems will occur.

Maintenance

The gas cylinders generally do not require any maintenance. Adjustments may be needed due to cable stretch.

When adjusting the cylinder it is important that you do not damage the stem on the cylinder. Small scratches left by applying the jaws of pliers or Vice Grips directly to the shaft while making adjustments will destroy the seal and allow the gas inside the cylinder to escape. Use a piece of vinyl strapping, cloth or rubber to protect the cylinder shaft from the jaws of the tool you are using to make the adjustments!

Troubleshooting the Cylinders

Often, when experiencing problems with cylinders on BRODA wheelchairs, the cylinder is not damaged, it usually only requires an adjustment. There are two common adjustments.

1. The pin that the cable handle pulls on at the end of the cylinder is not connected correctly.
2. The handle or cable assembly is broken or disconnected.

Other solutions to common problems are listed below.

- **The wheelchair is not tilting when cylinder handle is pulled.**
The pin in the end of the cylinder is not being depressed when the handle is pulled. Action to take: See adjustment steps that follow
- **The wheelchair tilt seems to slowly slide out of position.**
The pin in the end of the cylinder may be still partially depressed. Action to take: See adjustment steps that follow.

Adjusting the Cylinders

Note: Cylinder does not need to be removed from the wheelchair to make this adjustment.

1. Loosen the lock nut located on the stem of the gas cylinder, next to the actuator, with a 17mm wrench.

2. From the above instructions, determine whether you want to wind the stem further into the actuator or further out of the actuator. You will need to wind the stem further into the actuator if the chair is not tilting (wind it clockwise) and wind it further out of the actuator if the chair is slowly sliding out of position. (wind it counter clockwise)
3. Check the function of the cylinder and repeat steps 3 & 4 until the cylinder functions properly.
4. Tighten the lock nut loosened in step 1.

Removing and Installing the Cylinders

1. Remove the 5/16" mounting bolt from the end of the cylinder (requires 2 x 1/2" wrenches).
2. Loosen the lock nut located on the stem of the cylinder by the actuator.
3. Wind the stem of the cylinder out of the actuator.
4. Wind the stem of the new cylinder into the actuator.
5. Reinstall the 5/16" mounting bolt.
6. Adjust the cylinder as per the above adjustment instructions.

5.6 Vinyl Straps

Maintenance

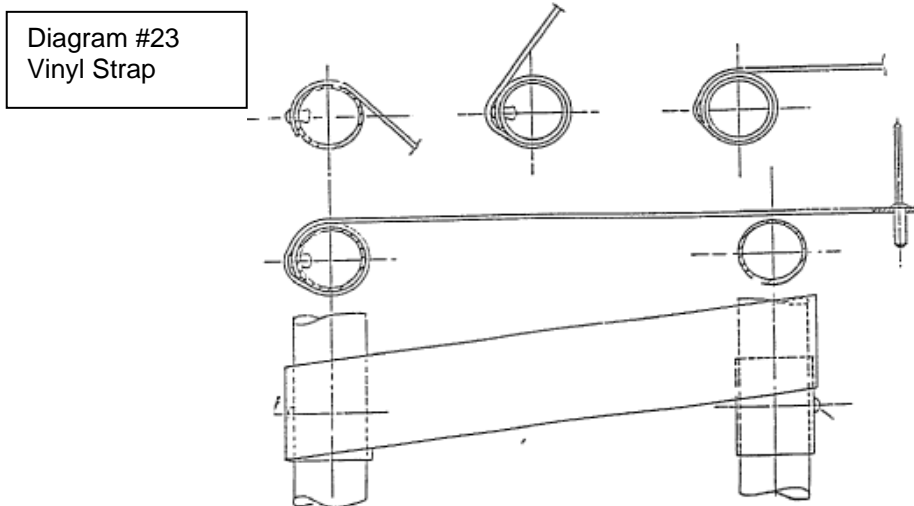

The only maintenance required for the vinyl strapping is general cleaning with an ammonia or chlorine based cleaner (Do not use petroleum based cleaners).

Installing and Replacing Vinyl Straps

The vinyl strapping has both elasticity and memory retention, which allows each strap to conform to the resident as an independent unit. Occasionally a strap may lose memory or be cut, making it necessary to replace them. The straps are installed under tension by heating the strap so that it is soft and pliable, enabling it to be easily stretched during installation. They are held in place by riveting them to the steel frame of the wheelchair and then wrapping them around the frame over the top of the rivet. This is done the same for both ends of the strap.

1. Remove the old strap by cutting it in two and drilling out the rivets with a 3/16" drill bit.
2. Heat the strap either by placing it in a pot of boiling water for a couple of minutes or by laying it out and heating it with a heat gun.
3. Rivet one end of the strap to the frame through the precut hole in the end of the strap, using a 3/16" diameter by 3/8" long rivet. Ensure the crowned or shiny side is facing up. Wrap the strap around the frame, over the top of the rivet.
4. Stretch the strap and wrap it around the other side of the frame next to the rivet hole (do not cover the rivet hole with the strap).
5. Rivet the other end of the strap, through the precut hole in the end of the strap to the frame.
6. Stretch the strap and move the offset strap over to cover the rivet.

Note: If the strap cools during installation, reheat it with a heat gun.

APPENDIX 1 - BRODA WARRANTY

BRODA Seating October 1999
(Division of BRODA ENTERPRISES INC.)
385 Phillip Street., Waterloo, ON N2L 5R8
PO Box 33046, G.P.O. Station, Detroit, MI 48232
Phone: (519) 746-8080 Toll Free 1-800-668-0637
Fax: (519) 746-8616

GENERAL INFORMATION WARRANTY

BRODA provides a Life Time Warranty on the wheelchair frame and cross braces, and a One Year Warranty on all other components subject to the following conditions:

No warranty is provided on seat pads or cloth covers.

The wheelchair frames and cross braces are guaranteed for the life of the chair against structural defects or failure. All other parts (except seat pads and cloth covers) including but not limited to strapping, cushions, gas springs and attachments, casters, wheels, brakes and armrests are guaranteed for one year against defects in materials and workmanship based on normal institutional use. The guarantee does not cover malicious or deliberate damage or damage from misuse.

Modifications to BRODA products or the use of non-BRODA supplied parts voids the warranty. This warranty does not cover shipping damage (see below).

BRODA will provide new or refurbished parts for installation by the owner at no cost following confirmation by the local BRODA Representative or the BRODA Head Office Customer Service Representative. On request, defective parts must be returned to the factory within thirty days of receipt of the replacement parts by the owner. If the defective parts are not returned to BRODA on request, the owner will bear the cost of the replacement parts on invoice from BRODA.

Warranty does not include on-site labor for the installation of warranty parts or warranty repairs. The owner may return to BRODA products for warranty replacement or repair by shipping items prepaid and insured to the factory. Warranty completed at the factory includes both materials and labor. Parts to be repaired or replaced at the discretion of BRODA. All returns to the factory require prior authorization from BRODA.

BRODA retains the right to make design and application changes without notice. All orders will be filled with BRODA's current models unless otherwise specified by the purchaser.

BRODA wheelchairs are designed for patient mobility, positioning, and comfort in specialty seating, however, the application of BRODA products shall remain the responsibility of the purchaser or user.

This warranty is not transferable.

RETURNS

BRODA Seating will not accept any returns without a prior Returned Goods Authorization Number. Please contact our Head Office Customer Service Representative at 1-800-668-0637 for assistance. Returns must be insured when shipped.

DAMAGED FREIGHT NOTIFY THE CARRIER OF ANY DAMAGE IMMEDIATELY

It is the responsibility of the person receiving the goods to examine cartons and goods before accepting receipt. Note all damages on the bill of lading and file a claim if necessary. Notify the carrier of any concealed damaged within a maximum of 48 hours.

BRODA insures all products for in transit damage, failure to notify the carrier of in transit damage voids both the insurance and the BRODA warranty. If you require assistance, please contact our Head Office at 1-800-668-0637

SALES TAX

Most BRODA products are G.S.T. Zero Rated and Exempt from Canadian Provincial Sales Tax. Purchasers maybe required to check with their Provincial or State Tax Office for purchaser tax payment.