

BRODA® SEATING

OPERATING INSTRUCTIONS

Acute Care Chair



Broda Seating
560 Bingemans Centre Drive Kitchener, ON Canada N2B 3X9
Phone: 1-800-668-0637 Fax: (519) 746-8616
www.brodaseating.com
E-mail: sales@brodaseating.com

Instructions for Use

Foreword	1
General Instructions	2
1.0 SAFETY INSTRUCTIONS	3
1.1 Before First Use	3
1.2 Application	3
1.3 Legal Restrictions	4
1.4 Position of Chair “Danger of Falling”	4
1.5 Position of Seat Tilt “Danger of Tipping”	4
1.6 Location of Chair “Danger of Tipping or Falling Objects”	4
1.7 Total Lock Wheel Brakes “Danger of Falling”	4
1.8 Re-Positioning of Patient “Danger of Clamping”	5
1.9 Unintended Movement “Danger of Falling or Collision”	5
1.10 Patient Clothing “Risk of Injury to Patient’s Skin”	5
1.11 Improper Restraint Use “Risk of Serious Injury”	5
1.12 Improper Use	6
1.13 Cleaning	6
1.14 Preventative Maintenance	8
1.15 Patient Specific Instructions	8
2.0 DEFINITIONS and TECHNICAL INFORMATION	8
2.1 Definitions	8
2.2 Technical Information	9
2.3 Shipping and Storage Specifications	9
2.4 Labels	10
3.0 CAREGIVER MANAGEMENT	11
4.0 OPERATION and MOVEMENT	12
4.1 Seat Tilt	12
4.2 Back Recline	12
4.3 Elevating Leg Rest	13
4.4 Flip Down Footrest	13
4.5 Adjusting Legrest Length	13
4.6 Wings	14
4.7 Shoulder Bolsters	14
4.8 Swing Away Removable Side Panels	14
4.9 Height Adjustable Armrests	15
4.10 Removable Seat and Back	15
4.11 Removable Seat and Back Covers	16
4.12 Casters	18
4.13 Accessories (Options)	18
4.14 Broda Tray	18
5.0 INSPECTION and FUNCTIONAL TESTING	19
5.1 Inspection	19
5.2 Functional Testing	19
6.0 PATIENT SPECIFIC INSTRUCTIONS (Additions to Section 1)	20
7.0 REPAIR AND MAINTENANCE	
7.1 Trouble Shooting for Cylinders	21
7.2 Cables and Handles	25
7.3 6” Casters	27
7.4 Vinyl Strapping	30
8.0 WARRANTY INFORMATION	31



Foreword

Congratulations on your purchase of a BRODA chair and thank you for your confidence in our company and our products.

BRODA Seating has assumed a leadership position in providing the optimum in re-positioning functions and mobility for residents of long term care institutions. BRODA chairs do not look like traditional chairs and offer unique advantages found only with a BRODA. We are sure that after learning about BRODA, you will be convinced that your residents' quality of life will be greatly enhanced by BRODA chairs.

BRODA's products were designed to be recommended by Professional Caregivers for residents who require long term care. The maximum benefit to the resident using this chair will be achieved with the advice and assistance of their Caregivers.

This manual will assist you in making the best use of the functional capabilities of the BRODA chair and ensure that you will quickly become familiar with its use.

If you have any questions about the safe and effective operation of your BRODA chair or accessories after reading this manual, immediately contact your local BRODA representative or our Head Office Customer Service personnel for further assistance.

Head Office:
BRODA Seating
560 Bingemans Centre Drive
Kitchener, Ontario Canada
N2B 3X9

Phone: (519) 746-8080 Toll Free Can/US: 1-(800) 668-0637
Fax: (519) 746-8616
E-Mail: sales@brodaseating.com Website: www.brodaseating.com

General Instructions

The instructions contained herein provide guidance on the safe and correct operation of a BRODA chair. Safety measures as described in Section 1 must be observed when operating the chair's functions or moving the chair. Only authorized caregivers should operate or move a chair.

Every person that is involved with the operation and maintenance of the BRODA chair, including the resident's family members, must read this instruction manual prior to moving or operating the functions of this chair. A copy of this instruction manual must always be available to these people. No person, including the resident's family members, who is unfamiliar with or is unwilling or unable to adhere to the safety and operating instructions contained herein, should be permitted to operate or move the chair.

A BRODA chair is designed for use within a Nursing Home, Hospital, or other Long Term Care facility where the potential users benefit from the assistance and care of professional caregivers.

The safety and operating instructions that are included in this manual are very important to the safe and effective operation of the BRODA chair. The resident specific instructions in Section 6 (as determined by the resident's professional caregiver responsible for their seating, from a part of the safety requirements detailed in Section 1) must be followed at all times.

BRODA accepts no liability whatsoever for damage or disruption caused by operating errors, failure to provide proper maintenance, or the disregard of the instructions contained in this manual including the resident specific instructions.

BRODA reserves the right to make changes to the specifications of the dimensions, functions, and components of its products. Any textual or diagrammatic representations provided are not necessarily exactly the same as the delivered products and are not required to obtain spare parts.

Each BRODA chair is provided with a unique, identifying serial number. This serial number should be maintained on the chair and with your equipment records for future reference to obtain spare parts or additional copies of the operating instructions.

1.0 SAFETY REQUIREMENTS

This section must be read by all operators of the BRODA chair before they attempt to use the product. It is the resident's primary caregiver's responsibility to ensure that only people who are familiar with the information contained in this manual are authorized to operate or move the chair.

1.1 Before First Use

BRODA chairs are provided fully assembled and ready to use after purchaser inspection, functional testing, and training requirements have been met. If the chair does not appear to be in ready to use condition upon receipt, immediately contact your supplier and do not put the chair into service until after your concerns have been resolved.

This manual must be read thoroughly by the caregiver(s) directly responsible for the resident's nursing care before the chair is put into service.

The chair must be visually inspected for damage, missing parts, and loose fittings (fasteners) prior to first use or testing the chair's functions. Functional testing must be successfully completed after visual inspection and before first use. These obligations apply both to the first use of the chair and to all subsequent uses. (as described in Section 5, Inspection and Functional Testing)

An in-service on the operation and safety issues, as described in this manual, must be given to the resident's caregivers prior to its first use. (As described in Section 3.0, Caregiver Management)

This manual must be read thoroughly by new caregivers, prior to the first time a new caregiver operates or moves the chair, after the chair has been put into service.

A resident's family members, who share some of the responsibility for a resident's care, may be considered as a caregiver after they have read this manual, received instruction on the chair's safe use by a professional caregiver, and a caregiver directly responsible for the resident's care has given their approval.

1.2 Application

The BRODA Acute Care Chair is intended for patients within an acute care setting, long term care institution, and/or hospitals that are under the care of professional caregivers. The Acute Care Chair is intended for medium care patients. The suitability and application of a BRODA chair is to be determined by a professional caregiver who is familiar with the seating needs of the patient using the chair. Any other use of the chair is excluded from possible liability claims.

The weight capacity of the Broda Acute Care Chair is 450 lbs.

The Acute Care Chair is not to be used in the shower. Use in the shower may cause the frame or components to rust, and will void the warranty.

The chairs are not explosion resistant and may only be used where there are no flammable gases or liquids present such as anesthetics or petroleum based cleaners.

BRODA chairs are designed for use with specific BRODA accessories and spare parts. Any use of non-BRODA spare parts or accessories with a BRODA chair is excluded from possible liability claims. Any use of BRODA spare parts or accessories on a non-BRODA product is excluded from possible liability claims.

1.3 Legal Restrictions

BRODA chairs may only be used as described in this manual and with proper regard for recognized health care and work place safety and accident prevention practices. BRODA chairs may not be operated or used with non-BRODA spare parts or accessories which could endanger patients, staff, or other third parties. The chair may only be moved or operated by caregivers or family members who can guarantee its correct operation because they have read and fully understood this manual and the safety issues discussed herein.

1.4 Position of Chair “Danger of Falling”

Immediately after a patient is transferred into a chair, we recommend that the chair’s seat be tilted sufficiently to prevent the patient from sliding or falling forward off the chair. The amount of seat tilt used should be determined by the patient’s caregiver who is responsible for seating.

We recommend the patient’s feet be correctly positioned on the footrests and slightly to fully elevated to prevent the patient from sliding or falling forward off the chair. The amount of elevation used should be determined by the patient’s caregiver who is responsible for seating.

1.5 Position of Seat Tilt “Danger of Tipping”

We recommend that the chair’s seat be tilted sufficiently to prevent an agitated patient from tipping the chair forward or backward, or from slumping and sliding in the chair. The amount of seat tilt used should be determined by the patient’s caregiver who is responsible for seating. Always ensure that the patient is properly positioned before operating the seat tilt.

1.6 Location of Chair “Danger of Tipping or Falling Objects”

We recommend that when a patient has been moved to their destination, the chair is placed where the patient cannot reach handrails or other objects, fixed or movable. This is to prevent the patient from pulling the chair over or pulling themselves off the seating surface and to prevent the patient from pulling movable objects onto the chair and themselves.

We recommend that the chair be used in a supervised area to prevent untrained patients, caregivers, or third parties from unauthorized operation, movement, or unsafe actions such as sitting or leaning on the reclined back, elevated footrest, or the armrests. These actions, if not prevented, put the chair at risk of tipping or damage to the chair.

We recommend that a chair only be located on a level surface to minimize the risk of tipping over.

1.7 Total Lock Wheel Brakes “Danger of Falling”

The special casters found on the BRODA chair have total lock brakes which prevent the wheels from turning and swiveling. The brakes must always be applied when:

- 1) the chair is not in use;
- 2) a patient is being transferred (moved) into or out of the chair; and,
- 3) the chair is not being moved by a caregiver.

It is important to note that if the wheel locks are applied while the patient is in the chair, that the caregiver does not leave the patient unattended, especially those patients who have the capability or tendency to move the chair and/or those who may be agitated. This could cause harm to the patient if they attempt to move the chair while the wheel locks are applied.

Note that adjusting the footrest may be easier for the caregiver with the brakes applied

Failure to follow these instructions will unnecessarily increase the risk of serious falls by patients, caregivers, or third parties caused by the chair unintentionally moving.

1.8 Re-Positioning of Patient “Danger of Clamping”

BRODA chairs offer the benefits of seat tilt, back recline, legrest/footrest elevation, and moveable arms. During the movement of any of these functions, the following safety measures must be observed:

- 1) The patient’s arms must be positioned inside the chair frame with their hands on their body.
- 2) The patient’s feet must be correctly positioned on the footrests.
- 3) All of the chair’s brakes have been applied.
- 4) Only one caregiver at a time attempts to operate the chair’s functions.
- 5) Only one chair function is operated at a time.
- 6) The rear wheels are in the trailing position, behind the chair frame.
- 7) The patients’ and caregivers’ body are clear of all pinch points before operating the chair’s functions.

Failure to follow these safety measures can put the patients’ or caregivers’ limbs at risk of injury. Patients who may be unaware of their body position or unable to maintain a safe body position are at the most risk of the danger from clamping and caregivers should be more cautious with these patients. A second caregiver may be required to ensure the safety of these patients during these operations.

1.9 Unintended Movement “Danger of Falling or Collision”

We recommend BRODA chairs for indoor use within an institution and where there is not enough slope to cause the chairs to move unaided. Chairs used where the surface is uneven or sloped are at risk of unintended movement and could become a serious danger to the patient, caregiver(s), or a third party. We recommend that BRODA chairs are located away from stairwells, elevators, and exterior doorways within a long term care institution.

Outdoor use is appropriate only under the strict supervision and full attention of a caregiver who is physically capable of preventing any unintended movement over any surfaces that are to be traveled on. We recommend that a second caregiver assist when the chair is moved over surfaces that could cause significant unintended movement.

1.10 Patient Clothing “Risk of Injury to Patient’s Skin”

We recommend that patients only be seated while they are fully dressed in clothing that meets the needs of their specific condition. Prior to the operation or movement of the chair, the caregiver must ensure that the patient’s clothes or bare skin do not come into contact with any moving parts.

1.11 Improper Restraint Use “Risk of Serious Injury”

We recommend that alternatives to physical restraints be used with patients while seated in the chair except under the specific instructions of the patient’s primary caregiver and if applicable with permission of the patient’s family or guardian. Physical restraints have been identified as a common cause of serious injury to patients while they are seated. We recommend that the primary caregiver responsible for seating first consider the re-positioning options available in the chair (tilt, recline, elevating legrest) to reduce the risks of sliding, falling, or self-injury.

1.12 Improper Use

The improper use of the chair can be dangerous to the patient, caregivers, or third parties through:

- 1) Unauthorized operation of the chair's functions.
- 2) Unauthorized movement of the chair.
- 3) Inappropriate use of the chair for a patient who has not been assessed by the caregiver responsible for their seating.
- 4) Failure to reposition the patient frequently in the chair
- 5) Attempted simultaneous operation of multiple chair functions by one or more caregivers.
- 6) Attempting to move the chair with the brake(s) applied.
- 7) Leaving the patient unattended in the chair near other objects.
- 8) Leaving a potentially agitated patient in an unsupervised area.
- 9) Leaving a patient unattended for a period of time
- 10) Leaving a patient in a chair on a sloping surface.
- 11) Leaving a chair unattended on a sloping surface.
- 12) Using non-BRODA accessories on the chair.
- 13) Using the BRODA chair at temperatures below 0 Celsius (32 Fahrenheit)
- 14) Using the BRODA chair as a shower or bathing chair.
- 15) Using the BRODA chair for any use other than its intended application

1.13 Cleaning

BRODA chairs should be wiped clean with soap and water. **A diluted household strength ammonia or chlorine based cleaner, as well as a hospital grade cleaner may be used if necessary.**

Refer to the following guide for cleaning certain staining agents (Applies to the Permablok3® vinyl, as per the vinyl manufacturer's recommendations) The frame and components of the chair can be cleaned using the same procedure as the vinyl.

The steps below are also located in the Cleaning Guide found on the back of the Broda chair

Staining Agent

Cleaning Procedure

Eye Shadow / Mascara	Step 1
Grease / Suntan Lotion / Chocolate	Step 1
Blood / Bodily Fluids	Step 2
Red Lipstick	Step 2
Oil Base Paint / Tar / Asphalt	Step 3
Other Tough Stains	Step 4 or 5*

Step 1: Remove excess spill with a damp cloth. Clean with a 1:1 mix of Ivory® liquid and water. Rinse with clean water and dry.

Step 2: Use a straight application of concentrated cleaners such as Formula 409® or Fantastik® Spray Cleaner. Then wipe with a clean cloth. If using a hospital grade cleaner, follow the diluting instructions on the label.

Step 3: Use a 1:1 mix of ammonia and water or a 1:4 mix of bleach and water. Rinse with clean water and dry.

Step 4: Use a straight application of naphtha (lighter fluid). Rinse thoroughly with clean water and pat surface dry.

Step 5: Use a 1:1 mix of isopropyl alcohol and water. If the stain persists, use straight alcohol. Rinse thoroughly with clean water and pat dry. If the stain remains, use a 1:1 mix of acetone and water. Rinse with clean water and pat surface dry.

***Note:** for cleaning that requires steps 4 or 5 – Use a soft cotton cloth saturated with the cleaning material and rub the stain in circles 10 times. Pat dry with another soft cotton cloth, and check results.

For best cleaning results, certain parts and padding on the chair should be removed: Instructions for removal of the following parts are located in this manual: **Ensure that the entire chair including removable and non removable parts is thoroughly cleaned.**

Pay close attention to the frame, sockets, fasteners, parts and casters, as well as the padding for an even, thorough clean.

Remove parts for cleaning if desired:

- 1) Wings (see removal and installation instructions on page 14)
- 2) Swing Away/Removable Arms (see removal and installation instructions on page 15)
- 3) Seat and Back (see removal and installation instructions on page 16)

Thoroughly clean all removable parts and padding, as well as the frame and components around the parts and padding that have been removed.

- 4) Although not fully removable, the legrest/footrest assembly may be adjusted for cleaning. The legrest can be elevated for easier access while cleaning (see elevating legrest instructions on page 18) The legrest is length adjustable. Adjust the legrest to its full range, to access the entire calf rest and surrounding parts for thorough cleaning.

If necessary, the following padding on the Acute Care Chair may be removed as well for cleaning:

- 1) Shoulder Bolsters
- 2) Neckrest
- 3) Seat and Back Pads
- 4) Lower Side Pads
- 5) Footpad

BRODA chairs should not be cleaned with petroleum based cleaners. Any petroleum based products that come in contact with any vinyl surface should be removed as quickly as possible. Petroleum based products make vinyl brittle and will damage the seating surface and cushions. Metal parts and cushions should be wiped completely dry after cleaning. **Do not launder vinyl padding.**

Do not allow the chair to air dry. Leaving the chair to air dry and not ensuring the entire chair is completely dry may cause the frame and components to rust. Solvents such as those found in spray lubricants should not be used on BRODA Chairs as they can damage moving parts

Frequency and method of cleaning the chairs should be determined by facility infection control protocols. If visibly soiled, thoroughly clean the chair immediately as per the cleaning instructions in this manual.

The cleaning instructions in this manual are guidelines only. Results may vary under actual conditions. The information does not relieve the user of proper and safe use of the product and all cleaning agents and consideration for the overall cleaning maintenance of the chair. Cleaning and care instructions must be followed in conjunction with facility infection control protocols.

BRODA will not accept warranty or liability claims on chairs that have not been cleaned according to the instructions or cared for in proper regard for patient, caregiver and third party safety and hygiene.. The use of certain agents may be harmful to the surface appearance and lifespan of the vinyl. BRODA assumes no responsibility resulting from the use of such cleaning agents to the vinyl.

Touch up paint is available for the powder coated frame. Please call Broda's Customer Service Department if touch up paint is required. Do not leave BRODA chairs outdoors as the frame is not UV protected. Leaving the chairs outdoors could cause the paint to peel.

Formula 409® is a trademark of the Clorox Company.
Fantastik™® is a trademark of DowBrands, Inc.
Trademark of the Dow Chemical Company
Ivory® is a trademark of Proctor and Gamble

1.14 Preventative Maintenance

The maintenance on a BRODA chair will vary with the amount of use and the condition of the patients using the chair. We recommend regular visual inspection for signs of wear, damage, loose or missing fittings, and other safety concerns. Also, periodic testing of the chairs functions is appropriate. If a breakage, defect, or operational problem is detected, the chair must be repaired, inspected and tested for function before it is returned to service. In regular use, after the initial inspection and functional testing, the chair should be inspected and tested on a bimonthly basis. The chair should be inspected and tested as often as each use if the chair is used:

- 1) By aggressive or agitated patients
- 2) By patients who have involuntary movement.
- 3) On irregular or sloped surfaces.
- 4) By patients weighing over 220 lbs
- 5) By any unauthorized person.

Do not use any lubricants that contain solvents. Solvents will damage many of the moving components in the chair. If necessary a white, food grade grease (lubricant) may be used on the sliding components in the chair.

1.15 Patient Specific Instructions

The professional caregiver responsible for the patient's seating shall add such additional instructions as are necessary for the safety and comfort of the patient using the chair based on their professional experience and knowledge of the patient's specific conditions and requirements. These instructions form a part of the Safety Requirements for using the chair with that patient and must be made available to all caregivers. (see Section 6.0)

2.0 DEFINITIONS and TECHNICAL INFORMATION

2.1 Definitions

"BRODA" means Broda Enterprises Inc. doing business as Broda Seating. BRODA "chair" refers to the Acute Care Chair.

"Acute Care Institution" refers to a Hospital, Rehab Facility, Nursing Home or other Health Care Facility that provides health and personal care to its patients

"Long Term Care Institution" refers to a Nursing Home, Hospital, or other Health Care facility that provides health and personal care to its residents on a long term basis.

"Patient" refers to an individual living or being cared for short term in a Health Care facility under the care of Professional Caregivers.

"Professional Caregiver" refers to the Doctors, Nurses, Therapists, Nurses Aids, Health Care Aids, and other Specialists who work in a Health Care Institution and provide health and personal care to its residents.

"Caregiver" refers to any person in a Health Care Institution who is appropriately trained to provide care or services to the patient or the chair used by the patient and may include the patient's family members or guardian.

“Seat Tilt” refers to changing the angle of the chair’s seat with respect to the chair frame (or ground) without changing the angle between the back and the seat.

“Back Recline” refers to changing the angle between the chair’s back and the chair’s seat.

“Footrest Elevation” (and legrest elevation) refers to changing the angle between the chair’s footrest (and legrest) and the chair’s seat.

“Transfer(s)” refers to the movement of a patient into or out of a chair with the assistance of their caregiver(s).

“Mechanical Transfer(s)” refers to the movement of a patient into or out of a chair with the assistance of their caregiver(s) using a patient lift or other assistive device that bears the weight of the patient.

“Safety Requirements” are the important information contained in Section 1 which must be followed to ensure the safe operation of the chair for the patient, caregivers, and third parties.

2.2 Technical Information

Chair Frame

The frame is all steel construction. The seat base, back, side panels, arms, wings, legrest, and footrest are powder-coated for durability and corrosion resistance.

Adjustments to the seat tilt, back recline, and independent legrest elevation functions are supported by a mechanical locking device designed to permit controlled movement during the operation of these functions. (See Section 4, Operation and Movement). No motors or other powered devices are used in the chair.

Casters

The front casters are 5 inch total lock casters with non-marking grey rubber tires and have a 220 lb. weight capacity. The rear casters are 6 inch directional lock rear casters with non-marking grey rubber tires and have a 330 lb. weight capacity. The casters require minimal maintenance. Lubrication or maintenance may be required in extreme conditions such as steam cleaning, pressure washing or autoclaving.

Side Panels and Wings

Swing-away and removable side panels provide lateral support to the patient at their thighs. The arms are height adjustable to provide the correct armrest height for the patient’s forearms. The arms extend to the front of the seat to aid the patient during transfers.

The Wings on the chair provide upper body lateral support. Shoulder Bolsters that attach to the wings accommodate variances in resident shoulder widths and heights.

Cushions

Standard cushions include: Neckrest cushion, Shoulder bolsters, Calf pad, Sole pads, Lower side pads, Upper side pads, and Seat and Back pads. The 34 ounce healthcare vinyl fabric covering is manufactured to meet the following requirements: DIN 75 200/ DIN 53 438; MVSS 302, M2;CAL 117, and Wyzenbeck Heavy Duty Abrasion Test. Removable seat and back pads are covered with an 8 ounce soft vinyl which meets CAN2-162. The cushions are designed to accommodate infection control needs by having minimal and strategically placed stitching to help prevent fluids and bacteria from entering.

2.3 Shipping and Storage Specifications

BRODA chairs should be shipped and stored in an upright position and not stacked higher than 3 boxes. No other materials should be shipped or stored on top of a BRODA box. BRODA boxes should not be placed on pallets.

BRODA chairs should be shipped and stored at temperatures between minus 20 degrees Celsius and plus 40 degrees Celsius. BRODA chairs should not be used until they are between 0 degrees Celsius and 30 degrees Celsius. BRODA chairs should be kept in a clean, dry environment. Do not leave BRODA chairs outdoors as the frame is not UV protected. Leaving the chairs outdoors could cause the paint to peel.

Upon receipt, we recommend that the shipping carton be immediately examined for damage. Any damage should be noted on the delivery receipt and a request for inspection by the transportation company should be made. The shipping carton should be opened immediately and the chair examined for concealed shipping damage. If the chair appears to be damaged, a concealed damage report should be immediately filed with the transportation company.

2.4 Labels

BRODA uses labels to assist caregivers to identify items which permit the operation of the Acute Care Chair's functions.

Recline Label (Blue)



Tilt Label (Tan)



Tilt and Recline Instruction (White)

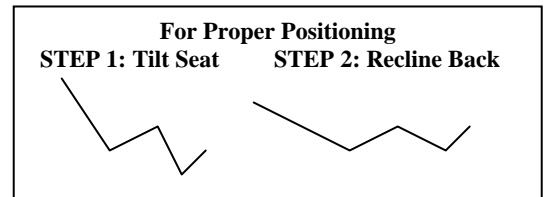

Serial Number Label (Gray)



Swing Away Armrest Label (Grey)

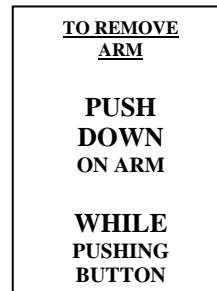

Manufacturers Label (White)

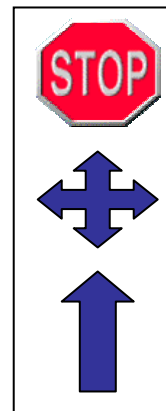

Multi Directional Caster Label (Grey)

3.0 CAREGIVER MANAGEMENT

BRODA Seating's unique and innovative chairs provide the optimum in re-positioning functions and mobility. However, BRODA's products were designed to be recommended by professional caregivers. The maximum benefit to the patient using this chair will be achieved with the advice and assistance of their caregivers.

The professional caregiver responsible for the patient's seating will add any additional resident specific instructions required for the safe and correct operation of the chair with a specific patient to Section 6.0 at the end of this manual. These additional patient specific instructions shall be considered as important additions to the Safety Requirements in Section 1

At the customer's request, the initial basic training of the patient's caregiver(s) in the operation of the chair will be provided by the local BRODA representative who supplies the chair. The caregiver(s) must adhere to the Safety Requirements at all times to ensure the safety of the patient, caregivers, and third parties.

The customer will maintain a list of caregivers who have read this manual and are authorized by them to operate and move the chair.

BRODA assumes no liability for damage, injury or accidents caused by careless, negligent, incorrect, or unauthorized operation or movement of its chairs.

4.0 OPERATION and MOVEMENT

Safety measures as described in Section 1 must be observed when operating the chair's functions or moving the chair. Only authorized caregivers should attempt to operate or move a chair. The caregiver must use proper body mechanics when operating the chair, and be prepared to support the weight of the patient while operating the chair.

4.1 Seat Tilt

The seat can be tilted to any position from the most upright to the lowest within its range. This assists the caregiver in changing a patient's body position to minimize slumping, falling or sliding forward. The tilt can also increase the stability of the chair to minimize the risk of tipping over and improve the patient's comfort. The Acute Care Chair has up to 27° of infinitely adjustable seat tilt.

To Activate the Seat Tilt:

- Locate the tilt handle on the left side of the chair (**figure 1.0**)
- Place right hand on bar to assist movement and squeeze tilt handle with left hand (**figure 1.1**)
- Raise or lower seat tilt until desired angle is achieved.
- Release the handle once the seat is in the desired position

Note: The ease of changing seat tilt may be affected by the weight of the person in the chair, or if the chair is unoccupied.

Standard Position



Tilt Position



Figure 1.0

Tilt Handle



Figure 1.1

4.2 Back Recline

The back can be reclined to any position from the most upright to the lowest within its range. This assists the caregiver in changing a patient's body position to: improve the patient's comfort and/or to assist caregivers in providing daily care activities. The Acute Care Chair has up to 90° of infinitely adjustable back recline. **Note: Always tilt slightly before reclining to prevent patient from sliding**

To Activate Back Recline:

- Locate the recline handle on the right side of the chair (blue label)
- Place left hand on bar to assist movement and squeeze recline handle with right hand (**figure 1.2**)
- Raise or recline the back until desired angle is achieved. (**figure 1.3**)
- Release handle once the back is in the desired position.

Note: Do not operate tilt and recline handles together
The Acute Care Chair is Trendelenburg capable. To achieve this position, recline fully then squeeze tilt handle

Recline Position



Figure 1.2

Recline Handle

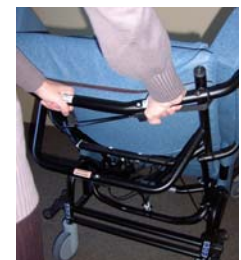

Figure 1.3

4.3 Elevating Leg rest

The Acute Care Chair leg rest articulates and extends with the back recline. This eliminates the need for repositioning the leg rest after reclining the patient in the chair. The leg rest can also be operated independently and is adjustable anywhere between vertical and horizontal. When the seat is tilted, the leg rest can be raised beyond vertical to become parallel with the seat angle.

To Adjust the Leg Rest Independently of the Back Recline:

- Locate the leg rest handle on the lower side of the chair (right side when facing the front of the chair) **(figure 1.4)**
- Hold the leg rest with your left hand and squeeze the handle with your right hand **(figure 1.5)**
- With your left hand, raise or lower the leg rest to the desired angle.
- Release the handle for leg rest to remain in desired position.

Note: The leg rest articulates with changes to the back recline but not with changes to the seat tilt. If the back is in the reclined position, the leg rest cannot be lowered independently

4.4 Flip Down Footrest

The footrest plate flips down to support the patient's feet while in the chair. The footrest plate also flips up to allow front transfers. **(figure 1.7)**

The footplate angle can be set at angles less than 90 degrees to accommodate ankle contractures. It can also be adjusted to greater than 90 degrees to accommodate foot drop.

To set the angle of the footplate to remain at less than 90 degrees, remove the footrest pad and flip up the footrest. Extend the bolt (as indicated at A) To make the angle extend more than 90 degrees, shorten the bolt (as indicated by B)

4.5 Adjusting the Leg rest Length:

The length of the leg rest is adjustable to accommodate various patients. It adjusts with a telescopic mechanism, and eliminates the need to remove the footrest for adjustment.

- Locate the leg rest adjustment handle (T-shape) behind the calf portion of the leg rest. **(figure 1.8)**
- With your right hand, pull the leg rest adjustment handle towards you. With your left hand on the footplate, pull out or push up on the leg rest to the desired length. **(figure 1.9)** Release handle.

Make sure all pinch points are clear when adjusting the leg rest length

Elevated Legrest



Figure 1.4 Leg rest Handle



Figure 1.5

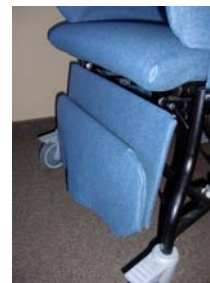

Figure 1.7

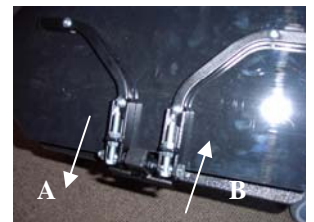

Figure 1.8
Adjustment handle



Figure 1.9

4.6 Wings

Wings support the shoulder bolsters which provide upper body lateral support to the resident. The wings can be removed by removing the bolts that attach the wings to the frame.

To Remove the Wings with Optional Upper Detent Pins (Buttons)

-Using your thumb, depress the top button found beside the wing on the chair back

-While depressing the button, pull the top of the wing frame from the receptacle. The wing may now be moved out of the way without its full removal.

-To completely remove the wing, depress the button on the lower portion of the wing frame and remove from the receptacle

To Insert the Wing

- Insert the lower end of the wing into the lower receptacle first. Then insert the upper end into the upper receptacle. Ensure the detent pin(s) and/or bolt are secured into place.



Bolt or optional detent pin (button)

Detent Pin (Button)

4.7 Shoulder Bolsters

The Shoulder Bolsters provide upper torso support, protection and containment. Individually adjustable, they accommodate asymmetries in the chair user. Their unique design allows for proper elbow access to the arm rest. The Shoulder Bolster is always used in conjunction with the side wing.

To Attach the Shoulder Bolsters

- Open the velcro flap on the bolster and slide the bolster on to the wing, with the padded side toward the inside of the chair. (figure 1.10)

- Close the velcro flap to secure the bolster to the wing frame. (figure 1.11)



Figure 1.10



Figure 1.11

4.8 Swing Away Removable Side Panels

The swing away side panels are an integral part of “No Lift” and “No Fall” programs. Side access can make transfers easier and safer for both the care givers and the chair user

-Push down on the front of the armrest. This removes the tension on the push button

-Locate the push button indicated by the label on the outer side of the chair (figure 1.12) and apply pressure to button with your thumb.



Figure 1.12

-Let the armrest “pop up”

-Swing the side panel away or remove completely
(**figure 1.13**)

Note: Chairs with Mag Wheels will not allow for the side panels to swing away, however they are removable

To Replace the Side Panels

- Insert the back end of the side panel into the back receptacle (**figure 1.14**)

- Swing the side panel until the front end is over the front receptacle

- Push the push button in to allow the front end into the front receptacle

- Push down on the front of the arm until the button pops into the button hole with a clicking sound (**figure 1.15**)



Figure 1.13



Figure 1.14



Figure 1.15 Button inserted into button hole

4.9 Height Adjustable Armrests

The armrest height can easily be adjusted in order to accommodate various residents. The arms are adjustable in 5/8” increments and have a height range of approximately 5.5”

How to adjust armrest height

- Lift up the flap on the outside of the side panel exposing the armrest height adjustment pins (**figure 1.16**)

- Squeeze the 2 pins together. DO NOT place fingers at the top of the pins as this could cause pinching. Place fingers in the concave shape of the pins. (**figure 1.17**)

- Raise or lower the arm to the desired height. (**Figure 1.18**) DO NOT place fingers anywhere underneath the arm while adjusting, as this could cause pinching. Upon releasing the pins the armrest height will lock into place

- Secure the outside flap on the side panel. Change the height on the other arm as desired



Figure 1.16



Figure 1.17



Figure 1.18

4.10 Removable Seat and Back

The seat and back are each removable from the frame for cleaning or replacement if necessary.

To remove the back:

- Locate the 2 bolts on the on the frame, just below the tilt handle (**figure 1.19**)
- Using a 7/16" wrench, loosen the bolts and remove the back from the back frame.

To insert the back:

- Place the back onto the back frame with the narrowest portion toward the bottom.
- Insert the bolts with spacers on the back through the frame to secure the back in place. Tighten the bolts (**figure 1.20**)

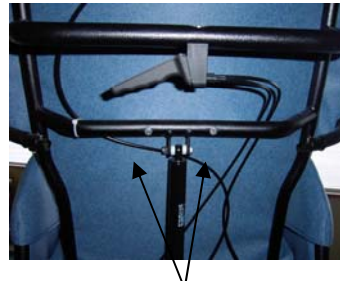

Figure 1.19



Figure 1.20

To remove the seat:

- Locate the 2 bolts on the frame underneath of the seat. The chair should be tipped on its back for easy access. (**figure 1.21**)
- Using a 7/16" wrench, loosen the bolts and remove the seat from the seat frame.

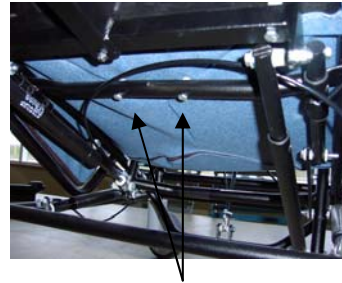

Figure 1.21

To insert the seat:

- Place the seat against the seat frame, aligning the bolts in the seat to the seat frame for attachment.
- Insert the bolts with spacers on the seat through the frame to secure the seat in place. Tighten the bolts.

4.11 Removable Seat and Back Pad and Cover

There are three separate and removable components to the seat: The strapped seat, the seat pad and the vinyl seat cover. The vinyl seat cover has minimal and strategically placed stitching to allow fluids to run off the chair for infection control purposes. The seat pad is 1" foam with a waterproof cover. The seams in the seat pad do not line up with the seams in the seat cover, to help prevent fluids from entering.

To remove the vinyl seat cover and pad:

- The seat must be removed from the frame first. (See above instructions 4.10)
- Undo the zipper on the cover and remove the padded seat.
- The seat pad can easily be removed from the strapped seat by simply releasing the seat from the edges of the seat pad.

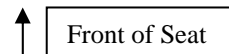

Strapped Seat (bottom)



Seat Pad (bottom)



Seat Cover (bottom)

To attach the vinyl seat cover and pad

- The seat must be removed from the frame first. (See above instructions 4.10)
- Attach the seat pad onto the strapped seat, making sure the front of the seat is inserted into the front of the seat pad. The front of the seat has 4 straps in front of the frame cross piece, and the rear of the seat has only 3 straps in front of the frame cross piece. The front of the seat pad has the longer fold. **(figure 1.22)**
- Insert the padded seat into the vinyl cover, with the zippered portion of the cover at the back of the seat. **(figure 1.23)**
- Once the padded seat is in place inside the vinyl cover, Close the zipper **(figure 1.24)**



Figure 1.22

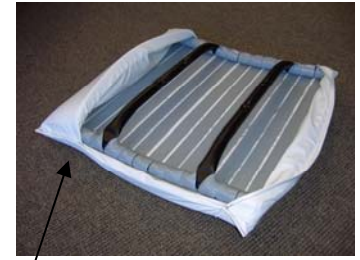

Front of Seat

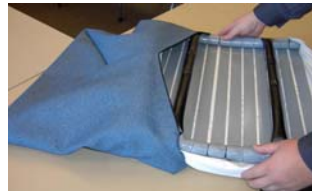

Figure 1.23

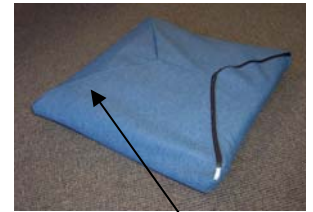

Figure 1.24

Front of seat

To remove the vinyl back cover and pad:

- The back must be removed from the frame first. (See above instructions 4.10)
- Undo the zipper on the cover and remove the padded back.
- The back pad can easily be removed from the strapped back by simply releasing the back from the edges of the back pad.

To attach the vinyl back cover and pad

- The back must be removed from the frame first. (See above instructions 4.10)
- Attach the back pad onto the strapped back, making sure the top of the back is inserted into the top of the seat pad. The top of the back is wider than the bottom. The top of the back pad has the longer fold. **(figure 1.25)**
- Insert the padded back into the vinyl cover, with the zippered portion to the top. **(figure 1.26)**



Strapped Back



Back Pad
Figure 1.25



Figure 1.26

4.12 Casters

Broda chairs come equipped with specially featured casters. The front casters are 5" Total Lock casters, which have a braking position controlled by a pedal. The rear casters are 6" Multi Directional Lock casters which have 3 different positions controlled by a butterfly pedal:

To operate the front casters:

- To engage the front caster brake, step on the brake pedal until the caster is in a locked position (**figure 1.22**)
- To disengage the front caster brake, step on the top pedal until the brake is released. (**figure 1.23**)



Figure 1.22



Figure 1.23

How to Operate Rear Casters

The rear caster function is controlled using the butterfly pedals above the casters. (**figure 4.1**)

1. For tracking position, use foot to position pedal so that back of pedal is pointing to the floor
2. For swivel position, use foot to position pedal so that pedal is parallel to floor
3. For braking position, use foot to position pedal so that front of pedal is pointing to the floor



Tracking



Swivel



Braking

← Front of chair

Note: Always ensure the brakes are not applied when wheeling the chair

4.13 Accessories (Options)

We recommend BRODA accessories for use only on BRODA chairs. The correct installation of the BRODA accessory is very important. We recommend that the BRODA chair is ordered with the required accessories already installed. Only authorized caregivers who thoroughly understand the accessory installation procedures should attempt to install their BRODA accessories without assistance from their local BRODA representative. BRODA does not recommend use of other manufacturer's accessories on BRODA chairs.

4.14 BRODA Tray



The optional BRODA tray is specially designed to work with your BRODA chair. Made of a single piece of durable ABS plastic, the tray securely slides over the arms of the chair to provide a level surface of meals or activities. A BRODA strap may be used to prevent the resident from accidentally pushing the tray off the chair. The strap should be buckled together behind the chair back below the armrests and as close to the level of the chair seat as possible. A tray strap with a side buckle is also available to meet non-restraining policies

Note: The BRODA tray is not to be used as a restraint. Using the tray as a restraint may cause harm to the resident, caregiver or third party.

Note: When inserting tray on to chair, ensure that residents' and caregivers' body are clear from pinch points to allow safe insertion of tray

5.0 INSPECTION and FUNCTIONAL TESTING

Safety measures as described in Section 1 must be observed when inspecting or testing a chair. Only authorized caregivers or maintenance staff should attempt to inspect or test a chair.

5.1 Inspection

We recommend regular visual inspection for signs of wear, damage, loose or missing fittings, and other safety concerns. If a breakage, defect, or operational problem is detected, the chair must be repaired inspected and tested for function before it is returned to service.

We recommend that the chair be inspected as often as each use if there is any reason to be concerned about the possibility of increased wear or loose or missing fittings. **At a minimum, in regular use the chair should be inspected on a bimonthly basis.** The visual inspection procedure should include at least the observation of the following fittings (fasteners):

- 1) The four bolts which attach the rear casters to the chair base.
- 2) The two bolts and two nuts which attach the front casters to the chair base.
- 3) The nuts and bolts that attach the 4 cylinders that position the seat tilt, back recline, and independent legrest elevation.
- 4) The two bolts and two nuts which attach the chair back to the rods the leg rest is attached to.
- 5) The two sets of two bolts and two nuts which attach the steel seat tilt rods to the chair base.
- 6) The two bolts and two nuts which attach the chair back to the chair seat
- 7) The two bolts and two nuts which attach the leg rest to the rods at the front of the chair
- 8) Each of the nuts and bolts on the footrest, especially those used for the adjustable footplate

The visual inspection procedure should include at least the observation of the following parts:

- 1) The 4 cylinders that position the seat tilt, back recline, and independent legrest elevation.
- 2) The vinyl straps used in the seat, back, legrest, footrest and wings
- 3) The cushions
- 4) The 3 black handles and cables.
- 5) The armrest height adjustment pins

We recommend the visual inspection procedure should include the observation of any installed accessories.

5.2 Functional Testing

We recommend that the chair should be tested for operation of the chair's functions without a resident in the chair. The testing may be as often as each use if there is any reason to be concerned about the possibility of increased wear or damage to the chair's components. At a minimum, in regular use the chair should be tested for functions as described in Sections 4.1 to 4.12.

If the caregiver or maintenance department performing the functional testing believes that any function is not operating correctly, the chair should be taken out of service until a satisfactory functional test can be completed.

The caregiver or maintenance department performing the testing should be aware that the seat tilt, back recline, and footrest (legrest) elevation operations will be more difficult without a resident in the chair.

When performing repairs or maintenance, do not use lubricants that contain solvents. Solvents will damage many of the moving components in the chair. If necessary, a white, food grade grease (lubricant) may be used on the sliding components in the chair. Do not use spray lubricants on any part of the chair.

7.0 REPAIR AND MAINTENANCE

7.1 Trouble Shooting for Cylinders

The use of gas charged springs on Broda products allow the caregiver to easily make adjustments to the tilt, recline, and leg rest with a minimum amount of effort. The gas cylinders contain Nitrogen gas, it is not flammable nor is it toxic. The cylinders provide a lifting force of 300 Newtons (approx. 68 Lbs). In other words the cylinders reduce the amount of weight the care giver has to lift by 68Lbs.

How do they work?

On the end of the stem of the cylinder is a small pin. When the operator depresses the handle, this pulls on the cable which in turn pulls on a small lever inside the actuator mechanism into which the stem of the cylinder is mounted. This depresses the pin, which in turn opens a valve located inside the barrel of the cylinder. This allows for changes in position. When the operator releases the handle the valve closes and locks the cylinder in the desired position.

Over the years Broda has used many different types of actuators to operate the gas cylinders used on our products. Although they may look different their function is one and the same (to push against the pin and open the valve that controls the cylinder). If the cylinder is not properly adjusted when mounted in the actuator, the cylinder may not function properly.

Maintenance

The gas cylinders do not require any maintenance, although they may need to be adjusted due to wide temperature variations or cable stretch.

When adjusting the cylinder it is important that you do not damage the stem on the cylinder. Small scratches left by applying the jaws of pliers or Vice Grips directly to the shaft while making adjustments will destroy the seal and allow the gas inside the cylinder to escape. Use a piece of vinyl strapping or rubber to protect the cylinder shaft from the jaws of the tool you are using to make the adjustments.

Trouble shooting:

Often when experiencing problems with cylinders on Broda chairs, the cylinder is not damaged, it just needs adjustment. There are two common adjustments.

1. **The pin that the cable handle pulls on at the end of the cylinder is not connected correctly.**
2. **Or the handle or cable assembly have become broken or disconnected.**

The cable mechanism works exactly like a bicycle brake and is easy to check when experiencing problems.

Other solutions to common problems are listed below.

1. **Chair is not reclining or tilting when cylinder handle is pulled.**
 - a. The pin in the end of the cylinder is not being depressed when the handle is pulled.
Action to take: See adjustment steps
2. **The chair seems to slowly slide out of position**
 - a. The pin in the end of the cylinder may be still partially depressed.
Action to take: See adjustment steps.

Adjustment Steps



Note: Cylinder does not need to be removed from the chair to make this adjustment.

1. Loosen the lock nut located on the stem of the gas cylinder next to the actuator (17mm or 11/16" wrench).
2. From the above instruction determine whether you want to wind the stem further into the actuator or further out of the actuator. **You will need to wind the stem further into the actuator if the chair is not tilting or reclining, (wind it clockwise) and wind it further out of the actuator if the chair is slowly sliding out of position. (wind it counter-clockwise)**



Note: When adjusting cylinders with tools that come in contact with the cylinder rods. A cloth, piece of vinyl strap, or some other protective material must be used to protect the sliding surface of the rod. If the rod becomes scratched or scarred it will puncture the seal on the cylinder and the cylinder will fail.

Damaging a cylinder in this fashion voids the manufacturer's warranty.

3. Wind the stem in the correct direction one half turn. When viewing the cylinder with stem pointing towards you turn the stem clockwise to wind the stem out of the actuator and counter-clockwise to wind the stem into the actuator.
4. Check the function of the cylinder and repeat steps 3 & 4 until the cylinder functions properly.
5. Tighten the lock nut loosened in step 1.

If adjusting the cylinder does not correct the problem, the cylinder may need to be replaced. Please contact Broda at 1-800-668-0637 or your local area representative.

Removal and Installation Steps



Actuator



1. Remove the 5/16" mounting bolt from the end of the cylinder (requires 2 x 1/2" wrenches).



2. Loosen the lock nut located on the stem of the cylinder by the actuator.



3. Wind the stem of the cylinder out of the actuator.
4. Wind the stem of the new cylinder into the actuator.



5. Reinstall the 5/16" mounting bolt.
6. Adjust the cylinder as per the above adjustment instructions.

Installing an Actuator



1. Hold the small pin in your right hand, with the long flat side, and the "u" cut out pointing upward.
2. Hold the head of the actuator in your left hand with the tail portion pointing to the right and the rounded head pointing up
3. Slide the small end of the pin through the hole, bringing it through just until it becomes flush with the side of the actuator



4. Holding the pin in place, wind the cylinder into the actuator, making sure the pin stays in place at all times
5. Tighten the actuator on the cylinder until the pin reaches the top of the hold in the actuator.
6. Using a wrench, tighten the bolt that will be located just underneath the attached actuator

7.2 Cables and Handles

Maintenance

The cables and handles do not require any maintenance.

Removal and Installation

The cable is used in conjunction with a cable handle and an actuator to control the function of the gas cylinder. The cable and handle are one unit. On the actuator end, the cable hooks into the lever that depresses the control pin on the cylinder. The cable housing either clips into the actuator housing or is held in place by a cable tie.

Steps:



1. Unclip the cable from the actuator.

BRODA Acute Care Chair



2. Cut the cable ties that secure the cable to the frame of the chair (carefully note the location of the cable ties and how the cable is threaded around the frame of the chair.)



3. Remove the mounting screw



4. Remount the new handle assembly to the frame of the chair using the screw removed in step 3.



5. Thread the new cable around the frame of the chair the same as the old one and install new cable ties where necessary.



6. Hook the end of the cable into the lever in the actuator and clip the cable housing into the actuator housing.



7.. Install a new cable tie around the end of the cable housing and the actuator, if the chair was originally equipped with one.

Note: This procedure may vary on earlier models.

7.3 6" Casters

Maintenance and Repair:

These casters are designed to be maintenance free. The bearings in these casters are permanently lubricated and should not require further lubrication. There are no adjustments or repair for this caster. Should the caster become defective, it must be replaced.

Replacement Instructions:

This caster has a stem that is inserted into the rear leg of the chair and is held in place by two mounting bolts located above the caster on the front and rear of the rear leg of the chair. The caster functions are controlled by pedals mounted on each side of the chair at the rear. These pedals control the function of casters at the same time and are mounted on a hexagonal shaft that run through the frame of the chair from one side to the other and are held in place by set screw located on the underside of the pedal. These casters must be synchronized with each other during installation as per the following instructions.

Steps:



1. Identify the caster that is not functioning properly.



2. Adjust the pedal so that the caster, which is still fully functional, is locked in the directional lock mode (the caster is locked from rotating and is trailing behind the chair and the wheel still spins).



3. If applicable, remove end caps on the end of the hexagonal shaft (in the middle of the pedal) Use a 3mm Allen-wrench to loosen the setscrew in the pedal beside the caster you are replacing. Remove the pedal from the hexagonal shaft. Check to make sure there are no burrs on the shaft where the pedal was secured. If there are burrs present use a file to remove them before proceeding to the next step.



4. Use a 13mm wrench to remove the mounting bolts that secure the faulty caster.



5. Slide the hexagonal shaft out of the frame of the chair approximately 6", on the side with the pedal still attached (next to the good caster).



6. Remove the faulty caster from the chair.



7. Holding the stem of the replacement caster in one hand determine if it is set in the directional lock mode (the caster housing should not rotate around the stem but the wheel still spins). If so skip to step 10.
8. Set the caster in the directional lock mode. By inserting a large flat blade screwdriver into the hexagonal hole located in the caster stem and rotating counter clockwise, when viewing the caster with

the blue side of the stem facing towards you, until it clicks. The head of a ¼” bolt will fit in the hexagonal hole and it can be held and rotated with a pair of locking pliers.



9. Hold the stem of the caster and swivel the caster housing until the directional lock engages. The caster won't swivel but the wheel still rotates in the fork.



10. Install the caster in the chair frame with the wheel trailing **behind** the chair the same as the other caster.



11. Reinsert the hexagonal rod through the new caster (a gentle tap may be required here).



12. Reinstall and tighten the mounting bolts (the use of Lock-Tite is recommended).



13. Reinstall the pedal removed in step 3 and tighten the setscrew. Insert new caps on the hexagonal shaft (in the middle of the pedal)

*Please note that after the end caps have been removed from the chair, they must be replaced with new ones. They are NOT reusable

7.4 Vinyl Strapping

Maintenance

The only maintenance required for the vinyl straps is general cleaning with an ammonia or chlorine based cleaners (Do Not use petroleum based cleaners).

Installation/Replacement Instructions

The vinyl strapping has both elasticity and memory retention this allows each strap to conform to the resident as an independent unit. Occasionally a strap may lose memory or be cut. This makes it necessary to replace them. These straps are installed under tension this is done by heating the straps so that they are soft and pliable and this enables them to be easily stretched during installation. They are held in place by riveting them to the steel frame of the chair and then wrapping them around the frame over the top of the rivet. This is done the same for both ends of the strap.

Steps: (see following page for illustration)

- 1) Remove the old strap by cutting it in two and drilling out the rivets with a 3/16" drill bit.
- 2) Heat the strap either by placing it in a pot of boiling water for a couple of minutes or by laying it out and heating it with a heat gun.
- 3) Rivet one end of the strap with a 3/16" diameter 3/8" long rivet, through the precut hole in the end of the strap to the frame with the crowned side of the strap up (shiny side).
- 4) Wrap the strap around the frame, over the top of the rivet.
- 5) Stretch the strap and wrap it around the other side of the frame next the rivet hole (do not cover the rivet hole with the strap).
- 6) Rivet the other end of the strap, through the precut hole in the end of the strap to the frame.
- 7) Stretch the strap and move the offset strap over to cover the rivet.

Note: If the strap cools off during the installation you can reheat it with a heat gun.

Vinyl Strap Installation:

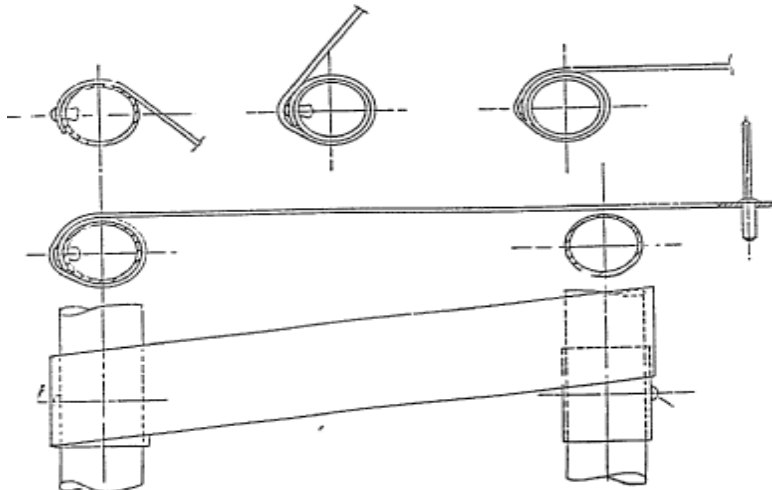

8.0

**BRODA SEATING
WARRANTY**

BRODA provides a Three Year Warranty on the chair frame, and a One Year Warranty on all other components subject to the following conditions:

The chair frames are guaranteed for three years against structural defects or failure. All other parts (including but not limited to) strapping, cushions, gas springs and attachments, casters, wheels, brakes and armrests are guaranteed for one year against defects in materials and workmanship based on normal institutional use. The guarantee does not cover malicious or deliberate damage or damage from misuse. The guarantee does not cover use of Broda chairs in a shower or pool, with the exception of the Broda Commode/Shower Chair.

Modifications to Broda products or the use of non-Broda supplied parts voids the warranty. This warranty does not cover shipping damage (see below).

BRODA will provide new or refurbished parts for installation by the owner at no cost following confirmation by the local BRODA Representative or the BRODA Head Office Customer Service Representative. On request, defective parts must be returned to the factory within thirty days of receipt of the replacement parts by the owner. If the defective parts are not returned to BRODA on request, the owner will bear the cost of the replacement parts on invoice from BRODA.

Warranty does not include on-site labor for the installation of warranty parts or warranty repairs. The owner may return to BRODA products for warranty replacement or repair by shipping items prepaid and insured to the factory. Warranty completed at the factory includes both materials and labor. Parts are to be repaired or replaced at the discretion of BRODA. All returns to the factory require prior authorization from BRODA.

BRODA retains the right to make design and application changes without notice. All orders will be filled with BRODA's current models unless otherwise specified by the purchaser.

BRODA chairs are designed for patient mobility, positioning, and comfort in specialty seating, however, the application of BRODA products shall remain the responsibility of the purchaser or user.

This warranty is not transferable.

RETURNS

BRODA Seating will not accept any returns without a prior **Returned Goods Authorization Number**. Please contact our Head Office Customer Service Representative at 1-800-668-0637 for assistance. Returns must be insured when shipped.

DAMAGED FREIGHT

NOTIFY THE CARRIER OF ANY DAMAGE IMMEDIATELY

It is the responsibility of the person receiving the goods to examine cartons and goods before accepting receipt. Note all damages on the bill of lading and file a claim if necessary. Notify the carrier of any concealed damaged within a maximum of 48 hours.

BRODA insures all products for intransit damage, failure to notify the carrier of intransit damage voids both the insurance and the BRODA warranty. If you require assistance, please contact our Head Office at 1-800-668-0637.

SALES TAX

Most Broda products are G.S.T. Zero Rated and Exempt from Canadian Provincial Sales Tax. Purchasers may be required to check with their Provincial or State Tax Office for purchaser tax payment.